

Compact Drills

3P606NT and 606NT

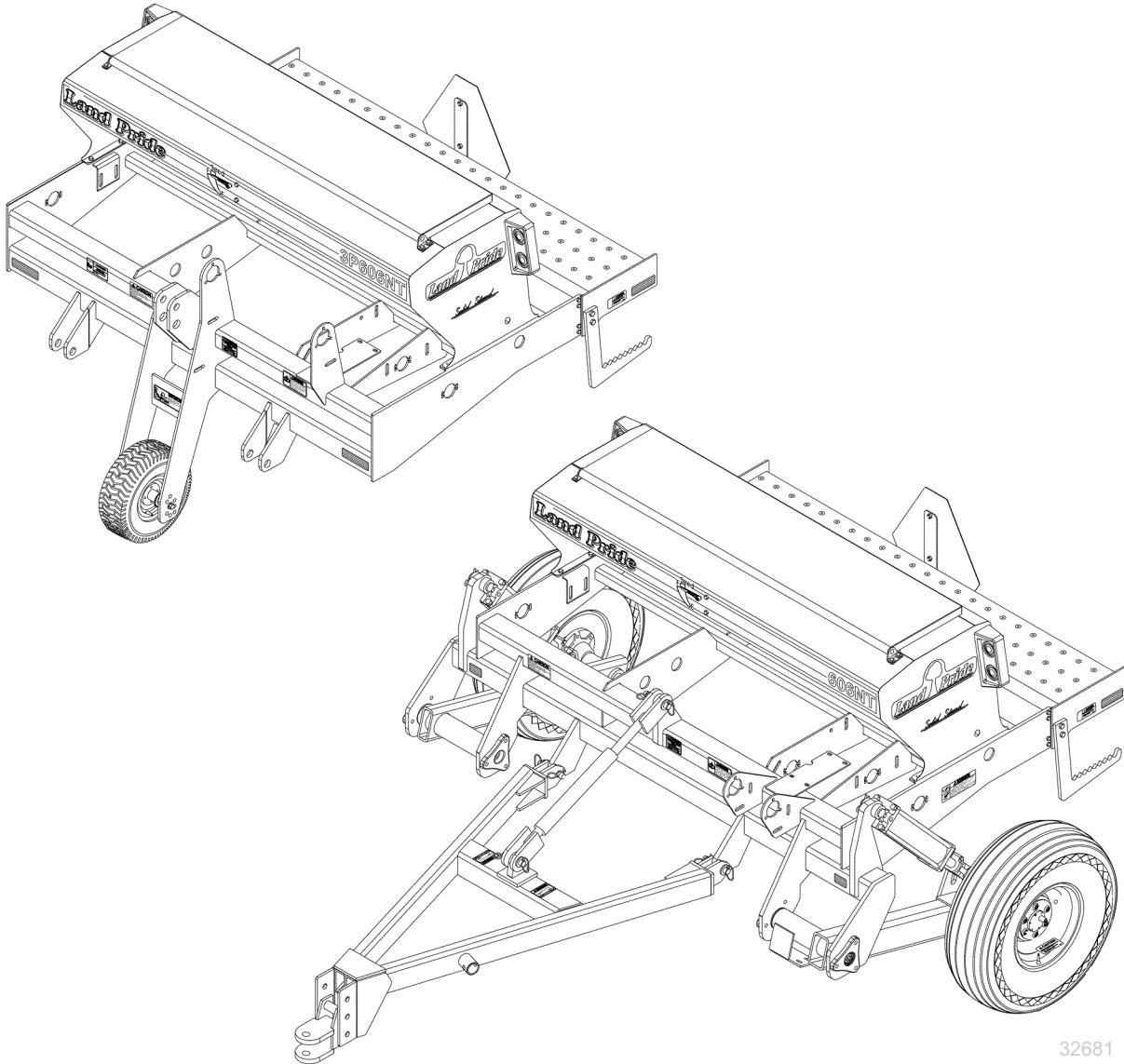

313-518M Operator Manual



Read the Operator's Manual entirely. When you see this symbol, the subsequent instructions and warnings are serious - follow without exception. Your life and the lives of others depend on it!

Cover photo may show optional equipment not supplied with standard unit. For an Operator's Manual and Decal Kit in another language, please see your Land Pride dealer.

Printed 2024-03-04



Machine Identification

Record your machine details in the log below. If you replace this manual, be sure to transfer this information to the new manual.

If you or the dealer have added options not originally ordered with the machine, or removed options that were originally ordered, the weights and measurements are no longer accurate for your machine. Update the record by adding the machine weight and measurements with the option(s) weight and measurements.

Model Number	
Serial Number	
Machine Height	
Machine Length	
Machine Width	
Machine Weight	
Year of Construction	
Delivery Date	
First Operation	
Accessories	 <hr/> <hr/> <hr/>

Dealer Contact Information

Name: _____

Street: _____

City/State: _____

Telephone: _____

Email: _____

Dealer's Customer No.: _____

 **WARNING:** Cancer and Reproductive Harm - www.P65Warnings.ca.gov

Section 1: Important Safety Information	1	Opener Spring	35
Safety Decals	5	Disc Blade Adjustments	36
Section 2: Introduction	10	Disc Scraper Adjustment	37
Description of Unit	10	Seed Firmer Adjustments	38
Intended Usage	10	Small Seeds Tube Adjustment (Option)	39
Models Covered	10	Opener Depth (Press Wheel Height)	39
Document Family	10	Section 6: Troubleshooting	40
Using This Manual	11	Section 7: Maintenance and Lubrication	43
Owner Assistance	11	Maintenance	43
Section 3: Preparation and Setup	12	Drive Idler Adjustment (606NT)	44
Pre-Setup Checklist	12	Seed Clean-Out	44
Hitching Tractor to Drill	12	Seed Flap Replacement	45
Hitching Model 3P606NT	12	Bleeding Hydraulics	46
Hitching Model 606NT	13	Chain Maintenance	47
Electrical Connections	14	Gearbox Maintenance	47
Height and Leveling the Drill	15	Lubrication and Scheduled Maintenance	48
Height Setup: Model 3P606NT	15	Section 8: Options	53
Height Setup: Model 606NT	16	Seed-Lok [®] Seed Firmer	57
Section 4: Operation Instructions	17	Section 9: Appendix A - Reference Information	59
Pre-Start Checklist	17	Specifications and Capacities	59
Transporting 3P606NT	18	Tire Pressures	60
Use an Adequate Tractor (3-Point)	18	Torque Values Chart	61
3P606NT Example Weights	18	Hydraulic Diagram	62
Transporting 606NT	19	Drive System Diagrams	63
Use an Adequate Tractor (Pull-Type)	19	Section 10: Appendix B - Pre-Delivery	67
606NT Example Weights	19	Tools Required	67
Use Transport Locks	20	Pre-Assembly Checklist	67
Loading Seed	22	Unloading	68
Main Seed Box Loading	22	Attach Meter Hoses at Rows	69
Loading Native Grass Box	22	Section 11: Appendix C - Accessory Installation	70
Loading Small Seeds Box	22	Carbide Disc Scraper Installation	70
Field Operation	23	Weight Bracket Installation	71
Re-Phasing Cylinders	23	Warranty	73
Parking	24		
Acrometer Operation	25		
Operating Instructions	25		
Acrometer Screens	26		
Storage	28		
Section 5: Adjustments	29		
Frame Weight Adjustment	31		
Coulter Adjustments	32		
Coulter Depth	32		
Coulter Down-Force	33		
Drive Clutch Adjustment	33		
06 Series Row Unit Adjustments	34		



© Copyright 2017 All rights Reserved

Land Pride provides this publication “as is” without warranty of any kind, either expressed or implied. While every precaution has been taken in the preparation of this manual, Land Pride assumes no responsibility for errors or omissions. Neither is any liability assumed for damages resulting from the use of the information contained herein. Land Pride reserves the right to revise and improve its products as it sees fit. This publication describes the state of this product at the time of its publication, and may not reflect the product in the future.

Land Pride is a registered trademark.

All other brands and product names are trademarks or registered trademarks of their respective holders.

Printed in the United States of America.

See previous page for Table of Contents



Important Safety Information

Look for Safety Symbol

The SAFETY ALERT SYMBOL indicates there is a potential hazard to personal safety involved and extra safety precaution must be taken. When you see this symbol, be alert and carefully read the message that follows it. In addition to design and configuration of equipment, hazard control and accident prevention are dependent upon the awareness, concern, prudence and proper training of personnel involved in the operation, transport, maintenance and storage of equipment.



Be Aware of Signal Words

Signal words designate a degree or level of hazard seriousness.

DANGER, and the color Safety Red, indicate an imminent hazard which, if not avoided, will result in death or serious injury. This signal word is limited to the most extreme situations, typically for machine components that, for functional purposes, cannot be guarded.



WARNING, and the color Safety Orange, indicate a potential hazard which, if not avoided, could result in death or serious injury, and includes hazards that are exposed when guards are removed. It may also be used to alert against unsafe practices.



CAUTION, and the color Safety Yellow, indicate a potential hazard which, if not avoided, may result in minor or moderate injury. It may also be used to alert against unsafe practices.



Prepare for Emergencies

- ▲ *Be prepared if a fire starts*
- ▲ *Keep a first aid kit and fire extinguisher handy.*
- ▲ *Keep emergency numbers for doctor, ambulance, hospital and fire department near phone.*



Be Familiar with Safety Decals

- ▲ *Read and understand "Safety Decals" on page 5, thoroughly.*
- ▲ *Read all instructions noted on the decals.*
- ▲ *Keep decals clean. Replace damaged, faded and illegible decals.*

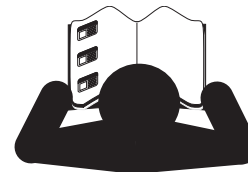

Wear Protective Equipment

- ▲ *Wear protective clothing and equipment.*
- ▲ *Wear clothing and equipment appropriate for the job. Avoid loose-fitting clothing.*
- ▲ *Because prolonged exposure to loud noise can cause hearing impairment or hearing loss, wear suitable hearing protection such as earmuffs or earplugs.*
- ▲ *Because operating equipment safely requires your full attention, avoid wearing entertainment headphones while operating machinery.*

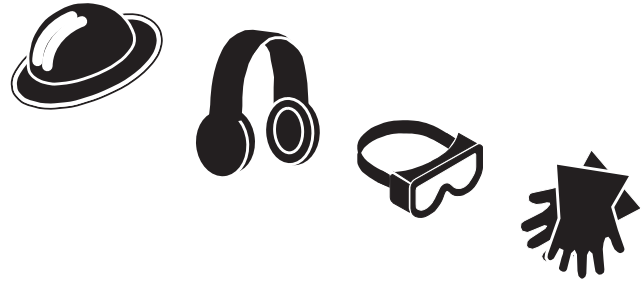

Handle Chemicals Properly

Agricultural chemicals can be dangerous. Improper use can seriously injure persons, animals, plants, soil and property.

- ▲ *Do not use liquid seed treatments with the 3P606NT or 606NT.*
- ▲ *Read and follow chemical manufacturer's instructions.*
- ▲ *Wear protective clothing.*
- ▲ *Handle all chemicals with care.*
- ▲ *Avoid inhaling smoke from any type of chemical fire.*
- ▲ *Never drain, rinse or wash dispensers within 100 feet (30 m) of a freshwater source, nor at a car wash.*
- ▲ *Store or dispose of unused chemicals as specified by chemical manufacturer.*
- ▲ *Dispose of empty chemical containers properly. Laws generally require power rinsing or rinsing three times, followed by perforation of the container to prevent re-use.*



Avoid High Pressure Fluids

(Model 606NT only)

Escaping fluid under pressure can penetrate the skin, causing serious injury.

- ▲ *Avoid the hazard by relieving pressure before disconnecting hydraulic lines.*
- ▲ *Use a piece of paper or cardboard, NOT BODY PARTS, to check for suspected leaks.*
- ▲ *Wear protective gloves and safety glasses or goggles when working with hydraulic systems.*
- ▲ *If an accident occurs, seek immediate medical attention from a physician familiar with this type of injury.*

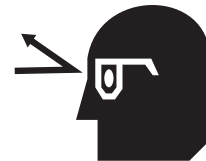

Use an Adequate Tractor

Model 3P606NT only:

- ▲ *Ensure that the tractor is rated for, and correctly ballasted for the drill's 3-point loading. Check that drill plus ballast does not exceed the tractor's capability.*
- ▲ *Avoid transport with material loaded in boxes.*

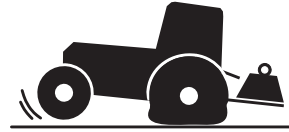

Model 606NT only:

- ▲ *Ensure that the tractor weighs at least $\frac{2}{3}$ (67%) of the drill (including the weight of any Options and materials).*
- ▲ *Avoid transport with material loaded in boxes.*

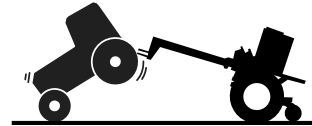

Use A Safety Chain

(Model 606NT only)

- ▲ *Use a safety chain to help control drawn machinery should it separate from tractor drawbar.*
- ▲ *Use a chain with a strength rating equal to or greater than the gross weight of towed machinery.*
- ▲ *Attach chain to tractor drawbar support or other specified anchor location. Allow only enough slack in chain to permit turning.*
- ▲ *Replace chain if any links or end fittings are broken, stretched or damaged.*
- ▲ *Do not use safety chain for towing.*

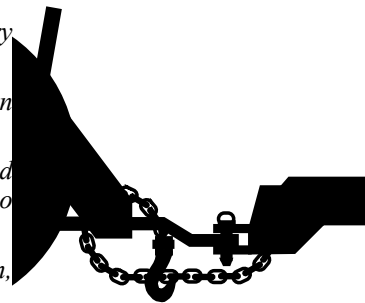

Keep Riders Off Machinery

Riders obstruct the operator's view. Riders could be struck by foreign objects or thrown from the machine.

- ▲ *Never allow children to operate equipment.*
- ▲ *Keep all bystanders away from machine during operation.*



Use Safety Lights and Devices

Slow-moving tractors and towed implements can create a hazard when driven on public roads. They are difficult to see, especially at night.

- ▲ *Use flashing warning lights and turn signals whenever driving on public roads.*
- ▲ *Use lights and devices provided with implement*

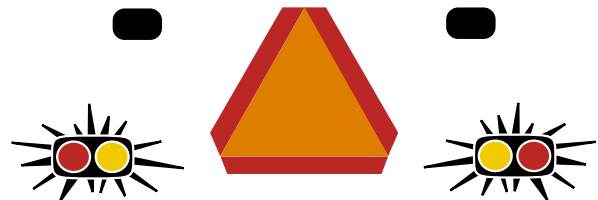

Transport Machinery Safely

Maximum transport speed for the implement on its own tires is 20 mph (30 kph). Rough terrain may require a slower speed. Sudden braking can cause a towed load to swerve and upset.

- ▲ *Do not exceed 20 mph (30 kph). Travel only at a speed which allows adequate control of steering and stopping.*
- ▲ *Comply with state and local laws.*
- ▲ *Carry reflectors or flags to mark drill in case of breakdown on the road.*
- ▲ *3-point implements reduce weight on steering tires. Verify that tractor is correctly ballasted. Watch for signs of poor steering traction.*

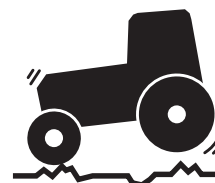

Shutdown and Storage

- ▲ *Park on level ground.*
- ▲ *Unhitch and store the drill in an area where children normally do not play.*

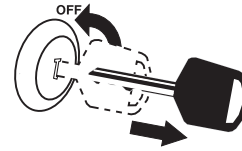

Tire Safety

Tire changing can be dangerous and should be performed by trained personnel using correct tools and equipment.

- ▲ *When inflating tires, use a clip-on chuck and extension hose long enough for you to stand to one side—not in front of or over tire assembly. Use a safety cage if available.*
- ▲ *When removing and installing wheels, use wheel-handling equipment adequate for weight involved.*



Practice Safe Maintenance

- ▲ *Understand procedure before doing work. Use proper tools and equipment. Refer to this manual.*
- ▲ *Work in a clean, dry area.*
- ▲ *Lower the drill, put tractor in park, turn off engine, and remove key before performing maintenance. If work must be performed with implement raised, use blocks or jackstands rated for the drill weight.*
- ▲ *Make sure all moving parts have stopped and all system pressure is relieved.*
- ▲ *Allow drill to cool completely.*
- ▲ *Disconnect battery ground cable (-) before servicing or adjusting electrical systems.*
- ▲ *Welding: Disconnect battery ground. Avoid fumes from heated paint.*
- ▲ *Inspect all parts. Make sure parts are in good condition and installed properly.*
- ▲ *Remove buildup of grease, oil or debris.*
- ▲ *Remove all tools and unused parts from drill before operation.*

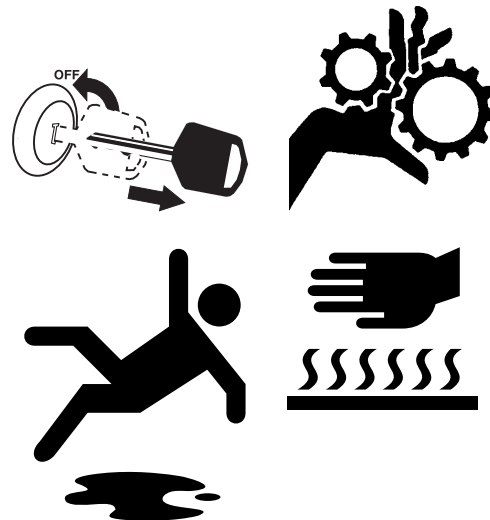

Safety At All Times

Thoroughly read and understand the instructions in this manual before operation. Read all instructions noted on the safety decals.

- ▲ *Be familiar with all drill functions.*
- ▲ *Operate machinery from the driver's seat only.*
- ▲ *Do not leave drill unattended with tractor engine running.*
- ▲ *Do not stand between the moving tractor and drill during hitching.*
- ▲ *Keep hands, feet and clothing away from power-driven parts.*
- ▲ *Wear snug-fitting clothing to avoid entanglement with moving parts.*
- ▲ *Make sure all persons are clear of working area.*

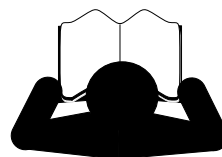

Safety Decals

Safety Reflectors and Decals

Your implement comes equipped with all lights, safety reflectors and decals in place. They were designed to help you safely operate your implement.

- ▲ *Read and follow decal directions.*
- ▲ *Keep lights in operating condition.*
- ▲ *Keep all safety decals clean and legible.*
- ▲ *Replace all damaged or missing decals. Order new decals from your Land Pride dealer. Refer to this section for proper decal placement.*
- ▲ *When ordering new parts or components, also request corresponding safety decals.*

Reflector: Slow Moving Vehicle (SMV)

818-055C



At center of walkboard;
1 total

See transport topic on page 18 or page 19.

To install new decals:

1. Clean the area on which the decal is to be placed.
2. Peel backing from decal. Press firmly on surface, being careful not to cause air bubbles under decal.

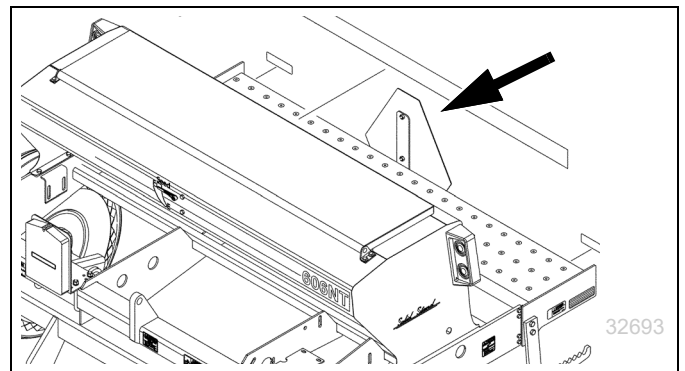

Reflectors: Red

838-266C



On rear face of walkboard, left and right ends;
2 total

See transport topic on page 18 or page 19.

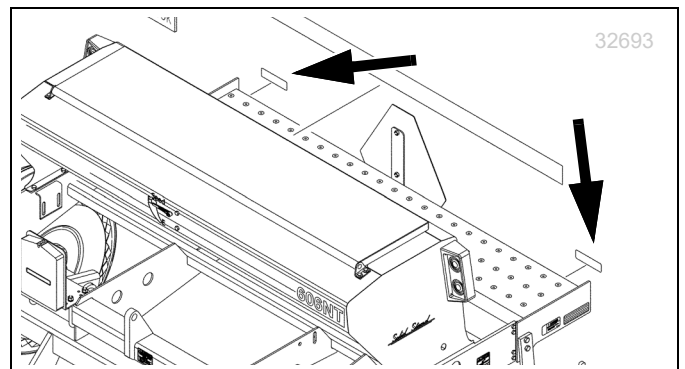

Reflectors: Amber

838-266C



On side frames at walkboard ends;
2 total

See transport topic on page 18 or page 19.

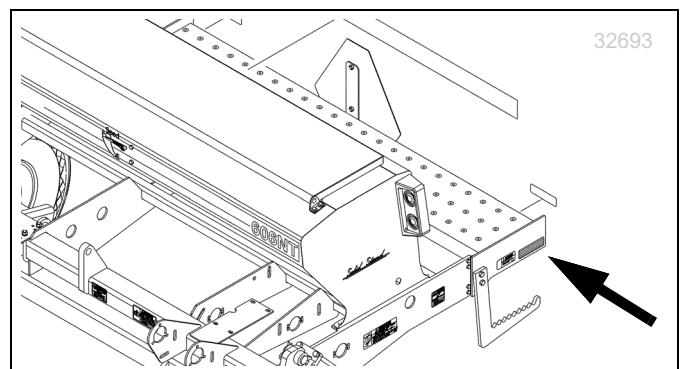

Reflectors: Amber (With Weights Option)

838-266C



On decal mounts attached to top front tool bar;
2 total

See transport topic on page 18 or page 19.

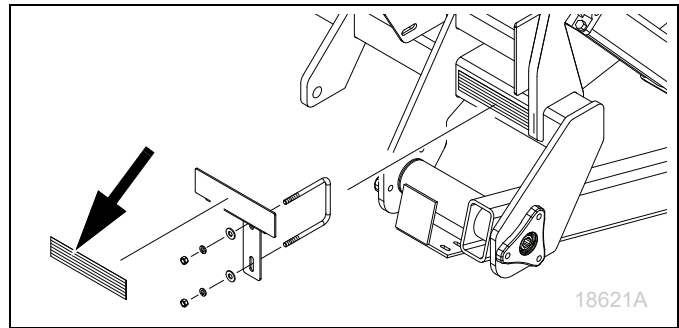

Danger: Hitch Crush

818-590C

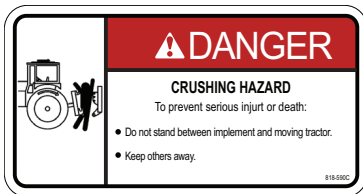

(3P606NT only)

Front face, each end of top front tool bar;
2 total

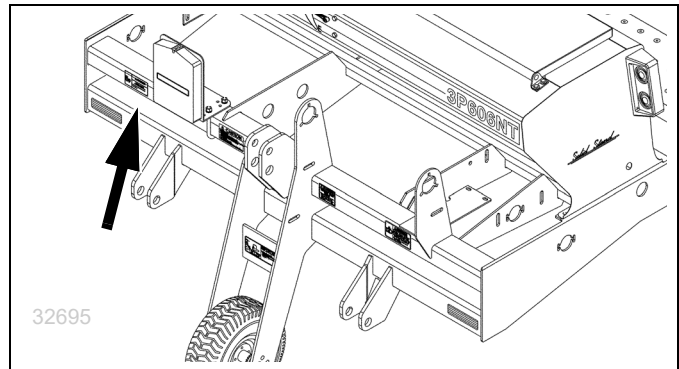

Danger: Possible Chemical Hazard (Option)

838-467C



(with Small Seeds Option only)

Under lid;
1 total

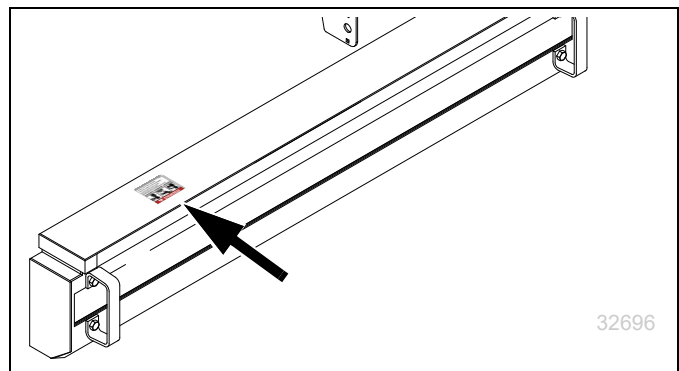

Warning: Speed

818-337C



On front face, upper front frame tube, left of center;
1 total

See transport topic on page 18 or page 19.

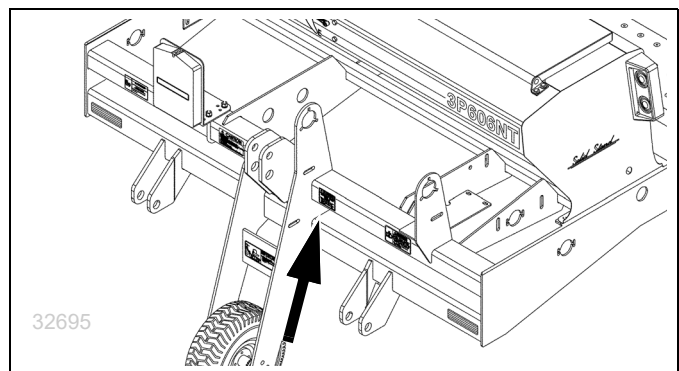

Warning: Moving Parts (standard)
818-860C



On front face, upper front frame tube, below gearbox;
1 total

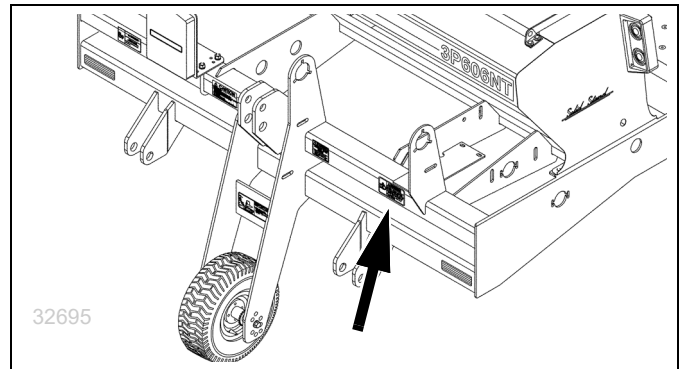

Warning: Moving Parts (Option)
818-860C



(with Small Seeds Option only)

On front face, upper front frame tube, below gearbox;
1 total

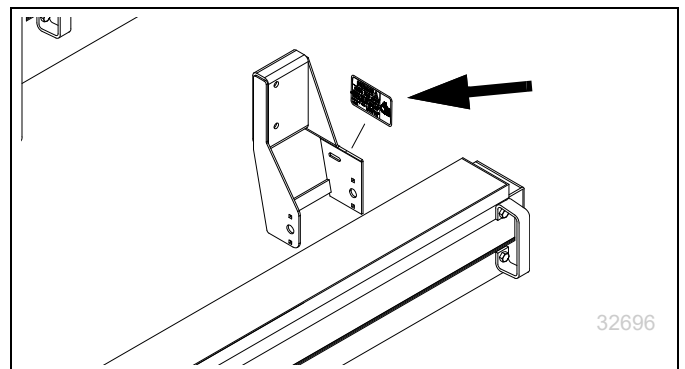

Warning: High Pressure Fluid
838-094C



(606NT only)
On side frames, near cylinder;
2 total

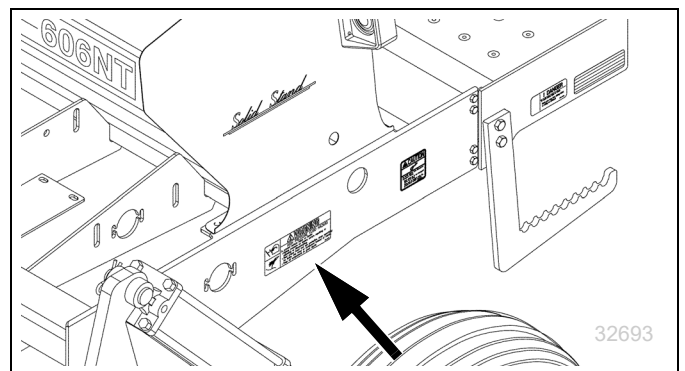

Warning: Falling Hazard
838-102C



On side frames at walkboard ends;
2 total
See “Loading Seed” on page 22.

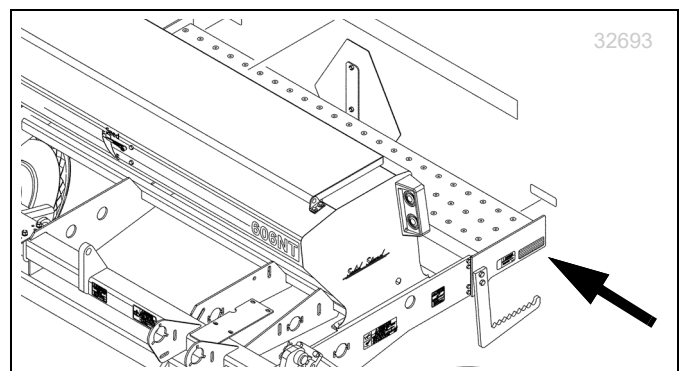

Warning: Clevis Adjustment
838-406C

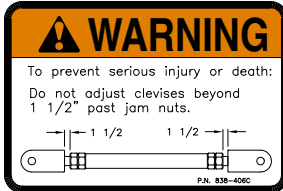

(606NT only)

On tongue cross-tube near turnbuckle;
2 total

See “Height and Leveling the Drill” on page 15.

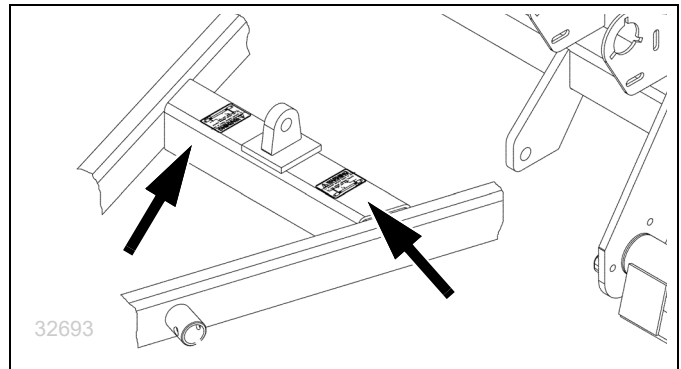

Warning: Crushing (Option)
838-611C

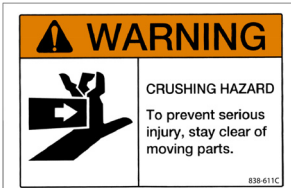

(optional Native Grass box)
On underside of lid;
1 total

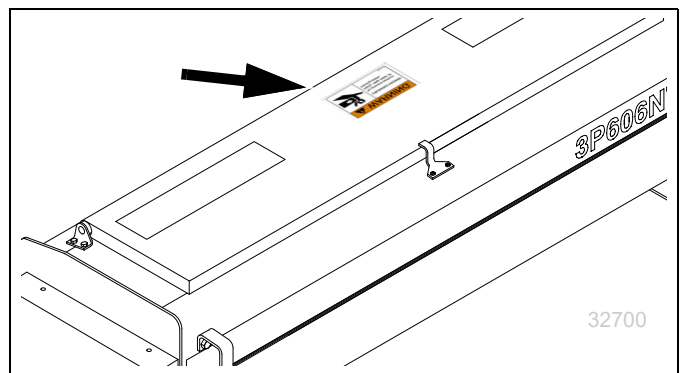

Caution: Tires Not A Step
818-398C



(606NT only)

On side frames above tires;
2 total

Tires may be in light contact with ground, or off the ground, when the drill is lowered.

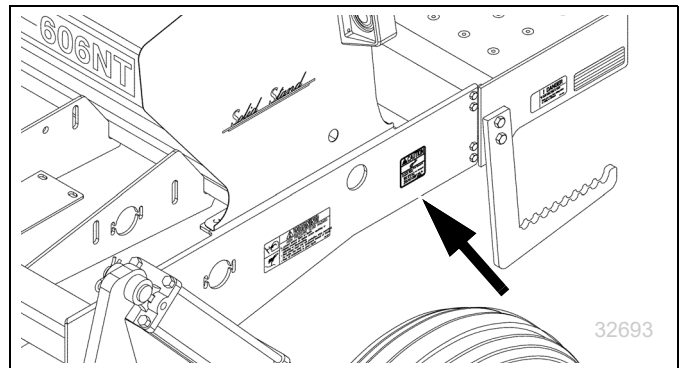

Danger: Moving Chain (Option)
818-518C



(optional Native Grass box)

On chain guard of Native Grass option box (left end);
1 total

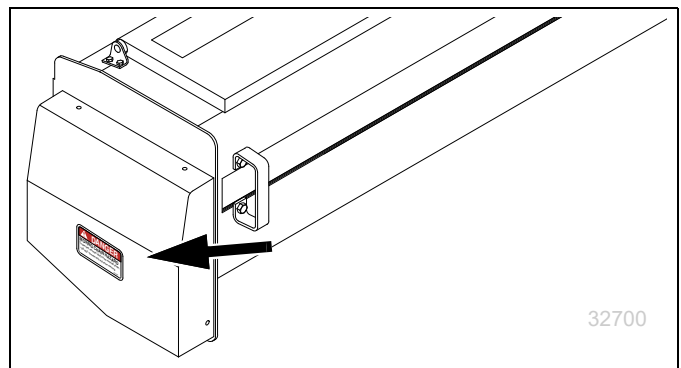

Caution: General
818-719C



3P606NT:
On front face, upper front frame tube, right of center;
1 total

606NT:
On front face, upper front frame tube, right end;
See "Important Safety Information" on page 1.

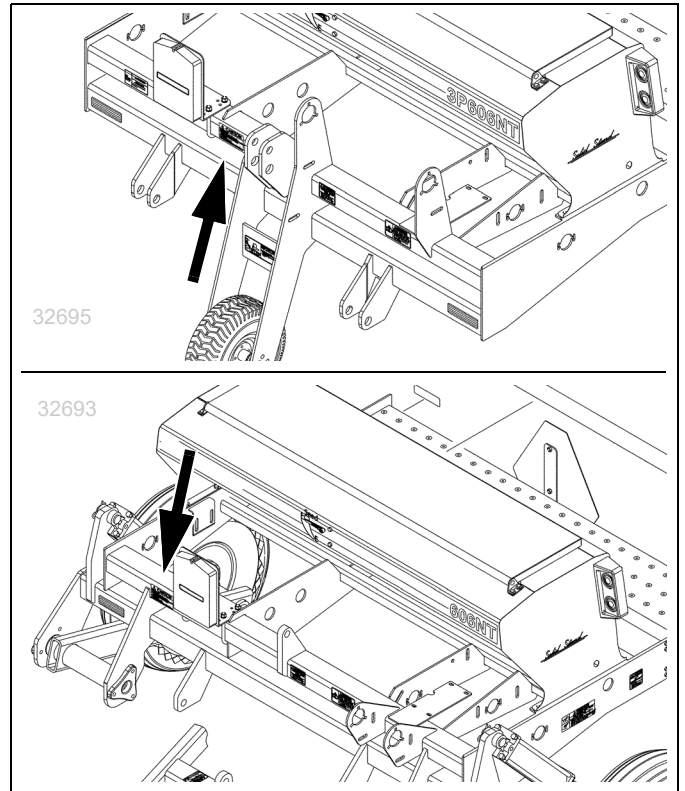

Caution: Tire Pressure and Torque
848-021C

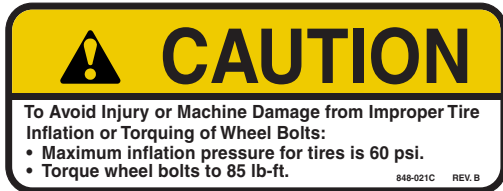

(606NT only)
On rim of each end wheel with 700-15 LT tires;
2 total

NOTICE: Petroleum Products 858-679C

PETROLEUM PRODUCTS UNDER CUP IN GRASS

(3P6006NT and 606NT only) On the left-hand ends of each seed box;
1 per seed box

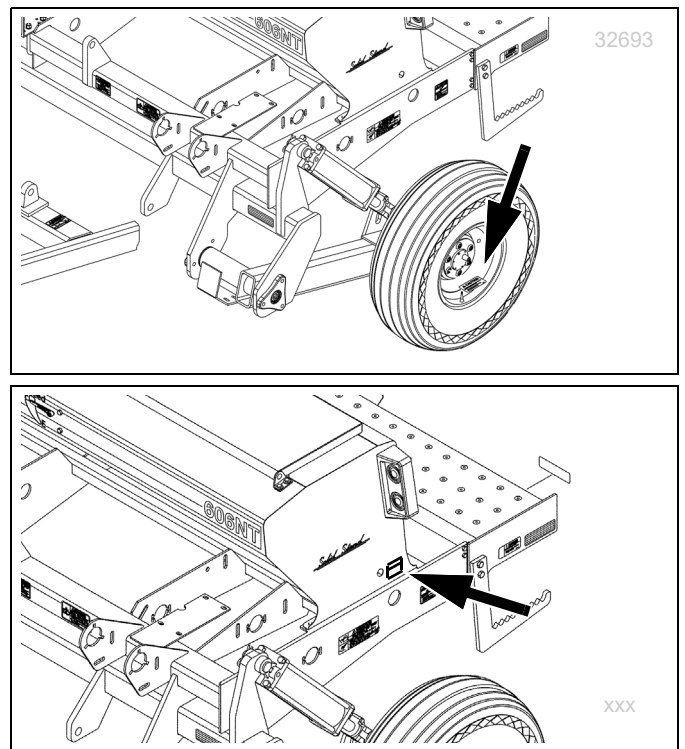

Introduction

Land Pride welcomes you to its growing family of new product owners. Your 6-Foot No-Till Drill has been designed with care and built by skilled workers using quality materials. Proper setup, maintenance, and safe operating practices will help you get years of satisfactory use from the machine.

Description of Unit

The 3P606NT is a 3-point seeding implement. The 606NT is a towed seeding implement. This drill has a working width of 7.5 feet (1.9 m). The drill has straight arm, double disc 05 or 06 Series openers. The opener discs make a seed bed, and seed tubes mounted between the discs place seed in the furrow. Press wheels following the opener discs close the furrow and gauge opener seeding depth. A T-handle on the opener body makes seeding depth adjustments.

The metering system is driven from the gauge wheel (3-point), or from the left end wheel (pull-type). Seeding rates are set by rate adjustment handles and a Drive Type gearbox for the main seed box.

Intended Usage

Use this implement to seed production-agriculture crops in conventional or minimum tillage applications.

Models Covered

This manual applies to Land Pride drill models:

3P606NT	9-row 7.5-inch (19.1 cm)
606NT	9-row 7.5-inch (19.1 cm)

Standard 3P606NT or 606NT Models have a main seed box. Native Grass and/or Small Seeds capability may be added.

Document Family

313-518M	Operator Manual (this document)
313-518P	3P606NT, 606NT Parts Manual
313-523B	Seed Rate Manual

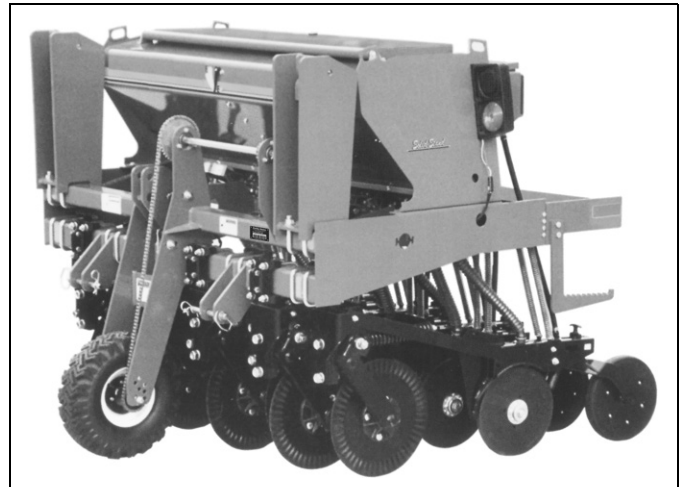

Figure 1
3P606NT No-Till Drill

32704

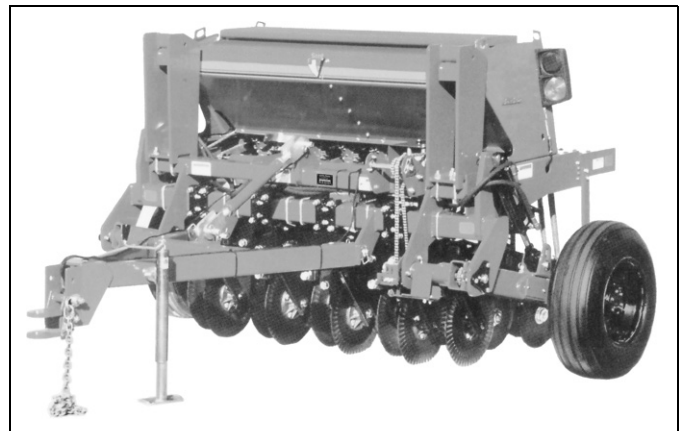

Figure 2
606NT No-Till Drill

32703

Using This Manual

This manual familiarizes you with safety, assembly, operation, adjustments, troubleshooting, and maintenance. Read this manual and follow the recommendations to help ensure safe and efficient operation.

Right-hand and left-hand as used in this manual are determined by facing the direction the machine will travel while in use unless otherwise stated. An orientation rose in some line art illustrations shows the directions of: Up, Back, Left, Down, Front, Right.

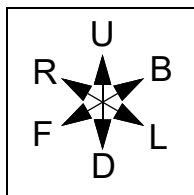

Note: This form sets off useful information related to the current topic, or forestalls possible misunderstanding.

The information in this manual is current at printing. Some parts may change to assure top performance.

NOTICE

Identifies an Economic (not a Safety) Risk: NOTICE provides a crucial point of information related to the current topic. Read and follow the instructions to avoid damage to equipment and ensure desired field results.

Owner Assistance

If you need customer service or repair parts, contact a Land Pride dealer. They have trained personnel, repair parts and equipment specially designed for Land Pride products.

Refer to Figure 3

Your machine's parts were specially designed and should only be replaced with Land Pride parts. Always use the serial and model number when ordering parts from your Land Pride dealer. The serial-number plate is located on the upper front frame tube, just left of center.

Record your drill model and serial number here and at the bottom of the Warranty page (inside back cover) for quick reference:

Model Number: _____

Serial Number: _____

Your Land Pride dealer wants you to be satisfied with your new machine. If you do not understand any part of this manual or are not satisfied with the service received, please take the following actions.

1. Discuss the matter with your dealership service manager. Make sure they are aware of any problems so they can assist you.
2. If you are still unsatisfied, seek out the owner or general manager of the dealership.

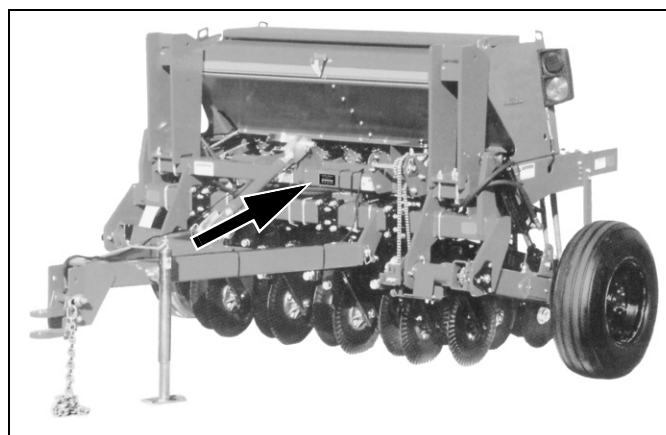
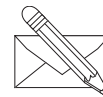

Figure 3 32703
Serial Number Location, 606NT

For further assistance write to:

Product Support
Land Pride, Service Department
PO Box 5060
Salina, KS 67402-5060



E-mail address:
lpservicedept@landpride.com

Preparation and Setup

This section helps you prepare your tractor and drill for use. Before using the drill in the field, you must hitch the drill to a suitable tractor and also setup the drill.

Pre-Setup Checklist

1. Verify that dealer pre-delivery is complete (page 67) and optional accessories are installed (page 70).
2. Read and understand “**Important Safety Information**” on page 1.
3. Check that all working parts are moving freely, bolts are tight, and cotter pins are spread.
4. Check that all grease fittings are in place and lubricated. See “**Lubrication and Scheduled Maintenance**” on page 48.
5. Check that all safety decals and reflectors are correctly located and legible. Replace if damaged. See “**Safety Decals**” on page 5.
6. Inflate tires and tighten wheel bolts as at “**Tire Pressures**” on page 60.

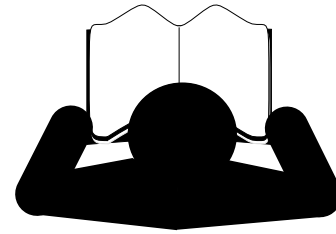

Hitching Tractor to Drill

Hitching Model 3P606NT

DANGER

Crushing Hazard:

You may be severely injured or killed by being crushed between the tractor and drill. Do not stand or place any part of your body between drill and moving tractor. Stop tractor engine and set park brake before installing the hitch pin.

NOTICE

Certain Machine Damage:

Remove tractor draw bar before hitching the 3P606NT. The drill drive wheel will be damaged if drawbar is not removed.

1. Raise or lower tractor 3-point arms as needed and pin lower arms to drill.
2. Pin upper arm to drill.
3. Slowly raise drill. Watch for cab interference.
4. Adjust top 3-point link so the top edge of drill box is parallel with the ground when drilling.

Note: Do not use link to adjust opener depth. For opener adjustments, refer to “**Opener Depth (Press Wheel Height)**” on page 39. Set your tractor 3-point draft control to Float position for planting.

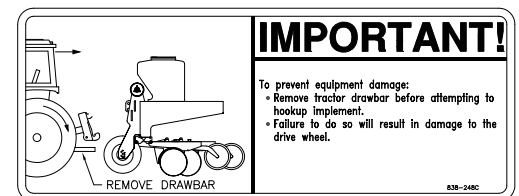
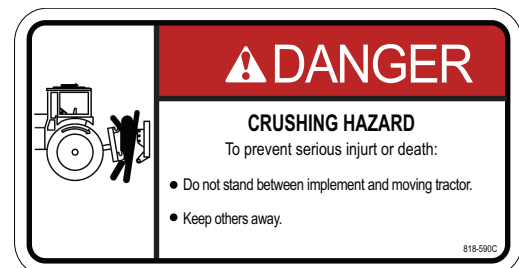

NOTICE

Equipment Damage Risk:

Due to interference with the gauge wheel assembly, drill models 3P606NT are not compatible with Great Plains accessory hitches CPH, PFH and SSH, nor with the Land Pride hitch set-back kit.

Hitching Model 606NT

CAUTION

Crushing Hazard:

You may be severely injured or killed by being crushed between the tractor and drill. Do not stand or place any part of your body between drill and moving tractor. Stop tractor engine and set park brake before installing the hitch pin.

1. With drill lowered in field position and tongue jack mounted as shown in Figure 4, raise or lower tongue jack to level drill tongue.

Refer to Figure 5

2. With drill tongue level, adjust drill hitch on drill tongue to match your tractor-drawbar height. You can move the hitch up or down or turn it over for a total of four different hitch heights.
3. When drill hitch matches tractor-drawbar height, hitch drill to tractor.
4. Securely attach drill safety chain to an anchor on tractor capable of pulling drill.



Figure 4
Jack in Parking Position

18473

Note: When hitching drill to a different tractor, check for a difference in drawbar heights. If heights are different, readjust hitch height accordingly.

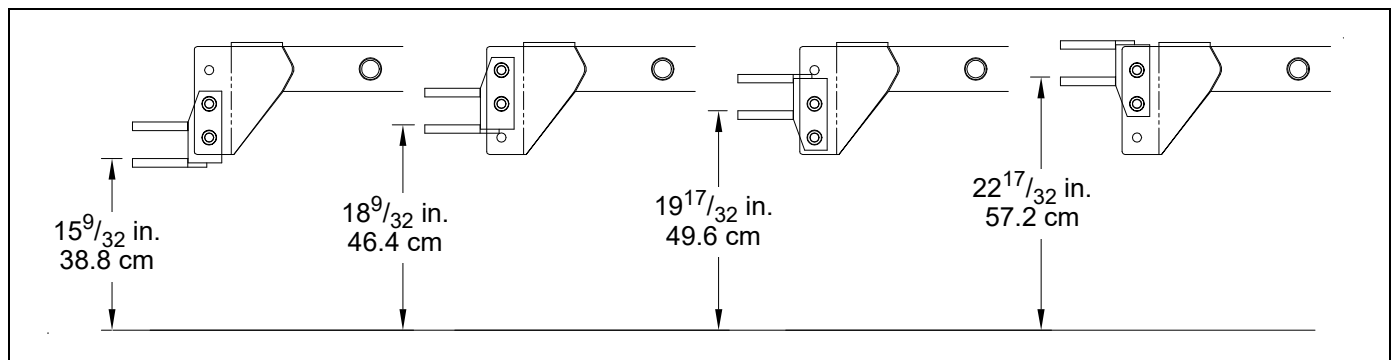

Figure 5
Clevis Hitch Height Adjustment

18544

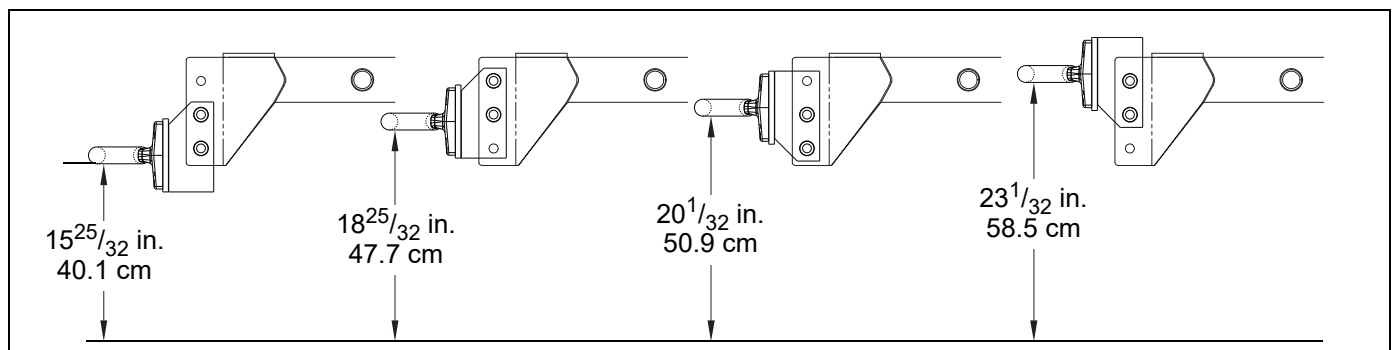

Figure 6
Pintle Hitch Height Adjustment

27216

Hydraulic Hose Hookup (606NT)

⚠ WARNING

High Pressure Fluid Hazard:

Shut down tractor before making hydraulic connections. Only trained personnel should work with system hydraulics. Escaping fluid under pressure can have sufficient pressure to penetrate the skin causing serious injury. Use paper or cardboard, NOT BODY PARTS, to check for leaks. Wear protective gloves and safety glasses or goggles when working with hydraulic systems. If an accident occurs, seek immediate medical assistance from a physician familiar with this type of injury.

Refer to Figure 7

Hydraulic hoses have directional handles and are color coded to help you hookup hoses to your tractor outlets. Hoses that go to the same remote valve pair are marked with the same color.

Color	Hydraulic Function
Blue	Transport Lift Cylinders

To distinguish hoses on the same hydraulic circuit, refer to the symbols on the handles. Hose under extended-cylinder symbol feeds cylinder base ends. Hose under retracted-cylinder symbol feeds cylinder rod ends.

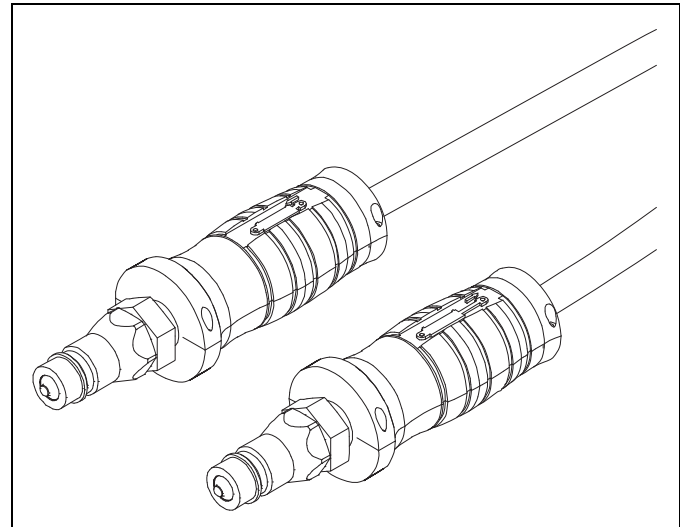

Figure 7
Hose Handles

31733

Electrical Connections

Refer to Figure 8

Plug drill electrical lead into tractor seven-pin connector. If your tractor is not equipped with a seven-pin connector, contact your dealer for installation.

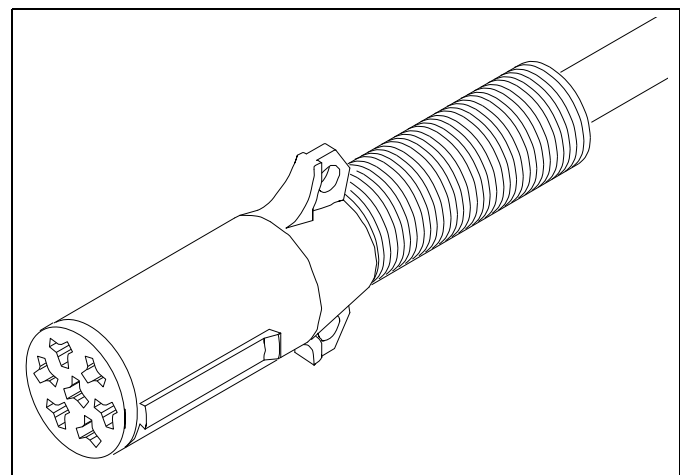

Figure 8
Lighting Connector

26467

Height and Leveling the Drill

Height Setup: Model 3P606NT

Refer to Figure 9 and Figure 10

1. Initially adjust drill so opener tool bar runs 24³/₄ in. (62.9 cm) above ground when drill is lowered in the field.
2. The drive wheel should be in the fourth mounting hole from the top (factory setting).

Note: The drive may need to be adjusted due to ground conditions.

3. Level drill with top 3-point link.

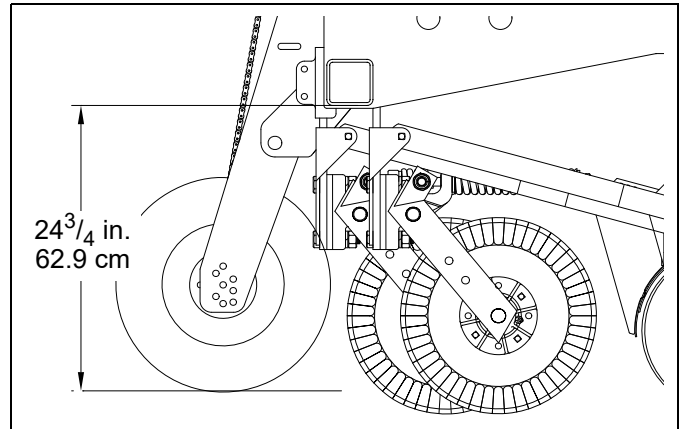

Figure 9
Initial Field Height,
3P606NT

18546

Adjusting 3-Point Height

Raising the gauge wheel spindle provides deeper coulters depth. Lowering the wheel provides shallower depth.

Note: Do not lower coulters to aid in penetrating hard soil. Instead, increase coulters down-force (page 33). This may require adding optional weight (page 31).

Refer to Figure 10

1. Determine new coulters depth desired. With new discs, the axle holes provide these depths:

Hole No. (from top)	Coulters Depth (n)	
	Inches	mm
1	3 1/2 in.	89 mm
2	2 7/8 in.	73 mm
3	2 3/8 in.	60 mm
4 (f)	1 7/8 in.	48 mm
5	1 3/8 in.	35 mm
6	7/8 in.	22 mm
7	3/8 in.	10 mm
8	1/4 in.	6 mm

f. Factory setting.

32774G

n. Depth is with new coulters blades.

2. Raise drill, unless wheel is already off ground sufficiently to allow wheel spindle relocation.
3. Relax chain idlers.
4. Remove wheel bolts. Move spindle to new hole pair. Re-install wheel bolts.
5. Re-engage chain idlers.

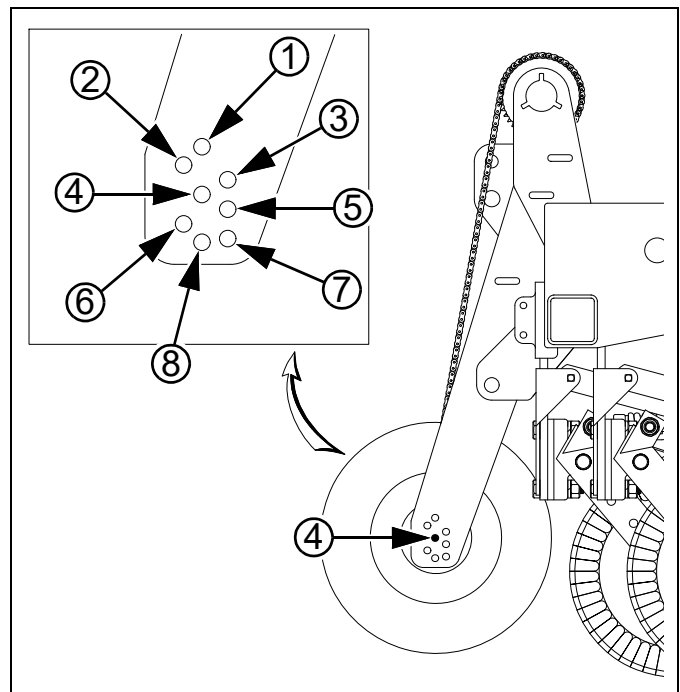

Figure 10
Height Adjustment,
3P606NT

18509

Height Setup: Model 606NT

Set Tool Bar Height

Refer to Figure 11 and Figure 12

Tool bar height ① is controlled by a depth stop assembly ② on the left lift cylinder.

The suggested initial tool bar operating height is:

① 24³/₄ in. (62.9 cm)
from the base of the opener tool bar to the ground, when lowered in field conditions (opener discs in ground).

1. Use the tractor remote circuit to raise the drill to the full extension of both lift cylinders. Hold the drill raised for several seconds to re-phase the cylinders. Remove any transport locks.
2. In field conditions, lower the drill to the desired tool bar height. Pull forward to put openers in ground. Set the remote to Neutral. Shut off the tractor.
3. Loosen the nut and bolt ③ that secure the stop weldment ④ to the cylinder rod.
4. Slide the weldment up the rod until it contacts the valve actuator ⑤, then slide it up another ¹/₈ in. (3 mm). Tighten the bolt.
5. Start the tractor. Raise and lower the drill. Pull forward in ground. The lowering stops when the weldment moves the actuator a short distance. Shut off the tractor and verify the tool bar height.

Note: If further adjustment is required, the drill height changes at approximately half the change in weldment position. For example, raising the drill another ¹/₈ in. (3 mm) would require moving the weldment up another ¹/₄ in. (6 mm).

Level Model 606NT

Refer to Figure 13

1. Use hitch turnbuckle ⑥ to level drill.
2. Lower unit to take weight off of drill. Do not adjust with unit in raised position.
3. Loosen jam nuts on hitch turnbuckle.
4. Turn turnbuckle to shorten or lengthen until top of drill frame is parallel to the ground being careful not to extend clevises beyond turnbuckle.
5. Retighten jam nuts on turnbuckle.

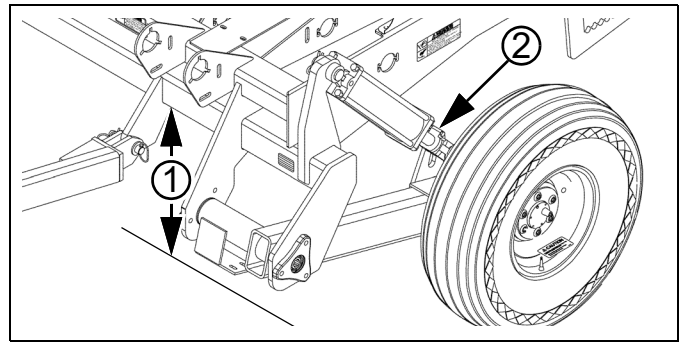
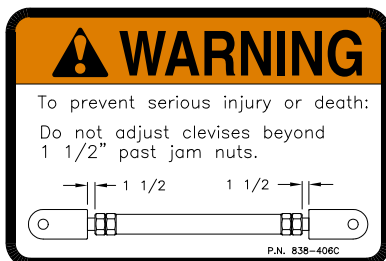

Figure 11
Pull-Type Tool Bar Height

32681

NOTICE

Field Results Risk:

Prior to first use, check tool bar height ① or the drill may run too deep. Model 606NT drills may be shipped with the depth stop valve actuator ② set to maximum depth. The actuator must be adjusted to desired opener height prior to first use.

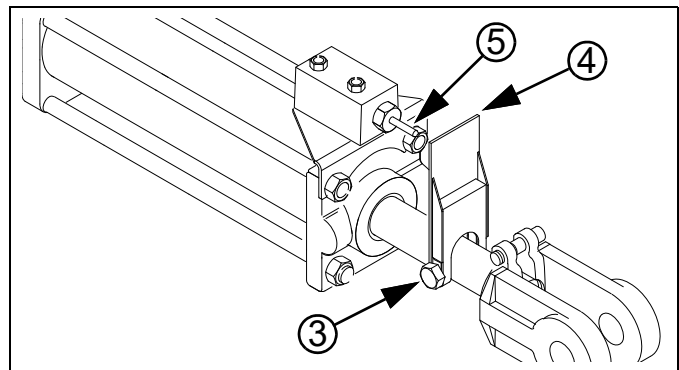

Figure 12
Cylinder Depth Stop

32712

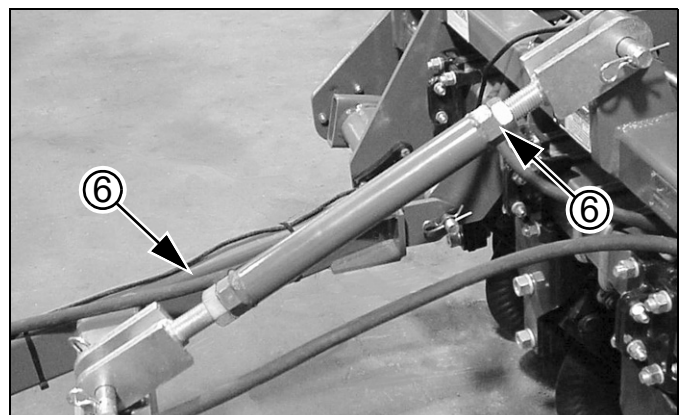
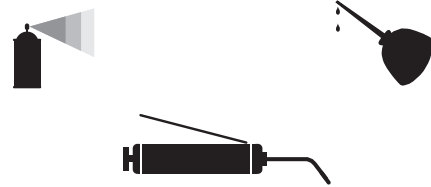

Figure 13
Pull-Type Turnbuckles

18513

Operation Instructions

This section covers general operating procedures. Experience, machine familiarity and the following information will lead to efficient operation and good working habits. Always operate farm machinery with safety in mind.



Pre-Start Checklist

⚠ WARNING

High Pressure Fluid Hazard:

Escaping fluid under pressure can have sufficient pressure to penetrate the skin. Check all hydraulic lines and fittings before applying pressure. Fluid escaping from a very small hole can be almost invisible. Use paper or cardboard, not body parts, and wear heavy gloves to check for suspected leaks. If an accident occurs, seek immediate medical assistance from a physician familiar with this type of injury.



- Carefully read “**Important Safety Information**” starting on page 1.
- Lubricate drill per “**Lubrication and Scheduled Maintenance**” starting on page 48.
- Check all tires for proper inflation. See “**Tire Pressures**” on page 60.
- Check all bolts, pins and fasteners. See “**Torque Values Chart**” on page 61.
- Check drill for worn or damaged parts. Repair or replace faulty parts before going to the field.
- Check hydraulic hoses, fittings and cylinders for leaks. Repair or replace faulty parts before going to the field.
- Rotate both drive wheel to verify that the drive and meters are working properly and free from foreign material.

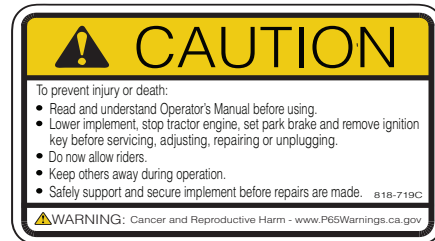

⚠ WARNING

Falling Hazard:

Watch your step when walking on drill steps and walkboard. Falling from drill could cause severe injury or death.



Transporting 3P606NT

Transport considerations are different for 3-point and pull-type models. For pull-type, see page 19.

Use an Adequate Tractor (3-Point)

⚠ DANGER

Loss of Control Hazard:

Insufficient weight on tractor steering tires can dangerously reduce steering authority, particularly during acceleration and ascending hills. You can lose directional control entirely, which could result in a major accident, serious injury, or death. Adding too much ballast could lead to brake or other mechanical failures, tire failures and loss of control.

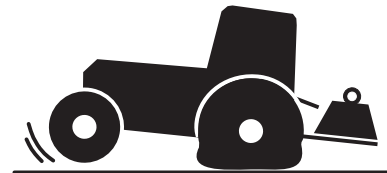

- ▲ *Ensure that the tractor is rated for, and correctly ballasted for the drill’s 3-point loading. Check that drill plus ballast does not exceed the tractor’s capability.*
- ▲ *If the drill has accessory weight brackets, consider moving any tractor weights present to the tractor during transport.*
- ▲ *Avoid transport with material loaded in boxes.*

The total drill weight and center of gravity vary considerably with drill configuration and material load. See table below.

3P606NT Example Weights

3-Point Drill Configuration	Typical Weights		
	Boxes Empty	Seed Loaded	Seed + Weights*
Standard Drill (Main Seed only)	2280 lbs	3000 lbs	3780 lbs
	1030 kg	1360 kg	1710 kg
Drill with Native Grass option	2580 lbs	3300 lbs	4080 lbs
	1170 kg	1500 kg	1850 kg
Drill with Small Seeds option	2430 lbs	3150 lbs	3930 lbs
	1100 kg	1430 kg	1780 kg
Drill with Native Grass & Small Seeds	2730 lbs	3450 lbs	4230 lbs
	1240 kg	1560 kg	1920 kg

* 151-058A82 Weight Kit plus 6 each 100 pound tractor weights, approximately 780 pounds.

Continue at “Transport Cautiously” on page 22.

Transporting 606NT

Transport considerations are different for 3-point and pull-type models. For 3-point, see page 18.

Use an Adequate Tractor (Pull-Type)

⚠ DANGER

Loss of Control Hazard:

Insufficient tractor weight can dangerously reduce steering authority, and increase braking loads beyond the capability of the tractor. You can lose directional control entirely, which could result in a major accident, serious injury, or death.

- ▲ *Ensure that the tractor weighs at least $\frac{2}{3}$ (67%) of the drill (including the weight of any Options and materials).*
- ▲ *Avoid transport with material loaded in boxes.*

The total drill weight varies considerably with drill configuration and material load. See table below.

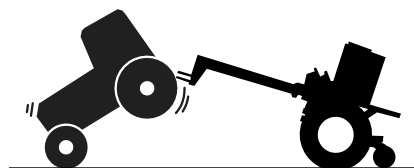

606NT Example Weights

Pull-Type Drill Configuration	Typical Weights		
	Boxes Empty	Seed Loaded	Seed + Weights*
Standard Drill (Main Seed only)	2700 lbs	3420 lbs	4200 lbs
	1220 kg	1550 kg	1910 kg
Drill with Native Grass option	3000 lbs	3720 lbs	4500 lbs
	1360 kg	1690 kg	2040 kg
Drill with Small Seeds option	2850 lbs	3570 lbs	4350 lbs
	1290 kg	1620 kg	1970 kg
Drill with Native Grass & Small Seeds	3100 lbs	3820 lbs	4600 lbs
	1410 kg	1730 kg	2090 kg

* 151-058A82 Weight Kit plus 6 each 100 pound tractor weights, approximately 780 pounds.

32774D

Use Transport Locks

CAUTION

Transport Hazard:

Failure of hydraulic cylinders during transport causes drill to drop suddenly, which could lead to a serious accident, injury or death. To prevent an accident, always install cylinder locks before transporting drill.

Before transporting the drill, check these items:

Cylinder Locks

Refer to Figure 14 or Figure 15, and Figure 16

A cylinder lock ① is provided for both gauge wheel hydraulic lift cylinders.

1. Raise drill completely. Set circuit to Neutral.
 2. Remove lock channels ① from storage locations.
 3. Place lock channels over rod ② of cylinder.
 4. Install cylinder lock pins ③ and retainer clips ④.
- Note: The cylinder lock can be secured or removed only after the drill is fully raised.
5. Unload drill box. The drill can be transported with a full box of grain, but the added weight increases stopping distance and decreases maneuverability. Unload drill box before transporting if at all possible.

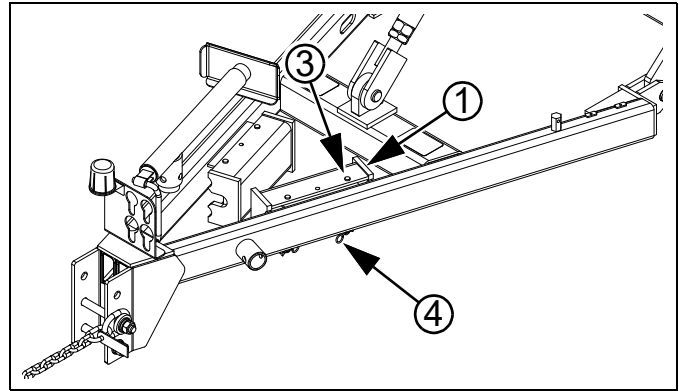

Figure 14: 2012+
Lift Cylinder Lock Storage

36177

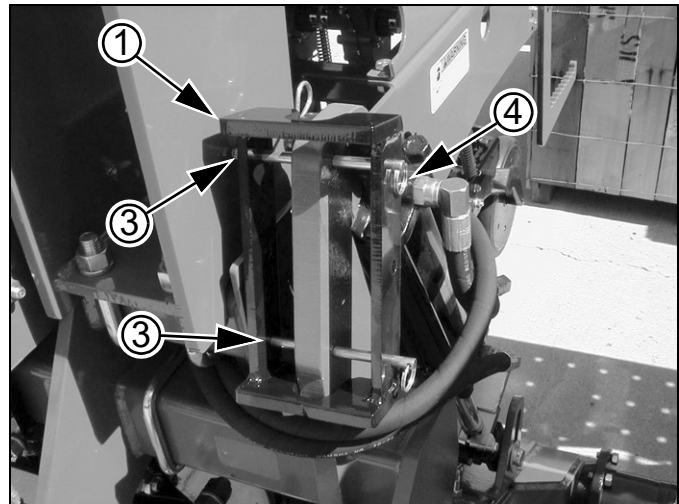

Figure 15: 2011-
Lift Cylinder Lock Storage

19653

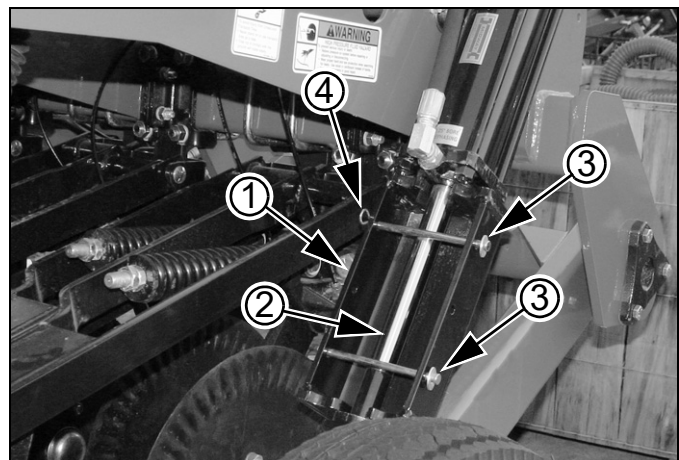

Figure 16
Lift Cylinder Lock (RH)

27217

Disengage Lock-Out Hub

Refer to Figure 17 and Figure 18

6. At lock-out on left hub, pull pin ⑤ away from wheel and rest in outer shallow detents ⑥. This disengages the hub from the drive train and prevents excessive wear of drive system during transport.

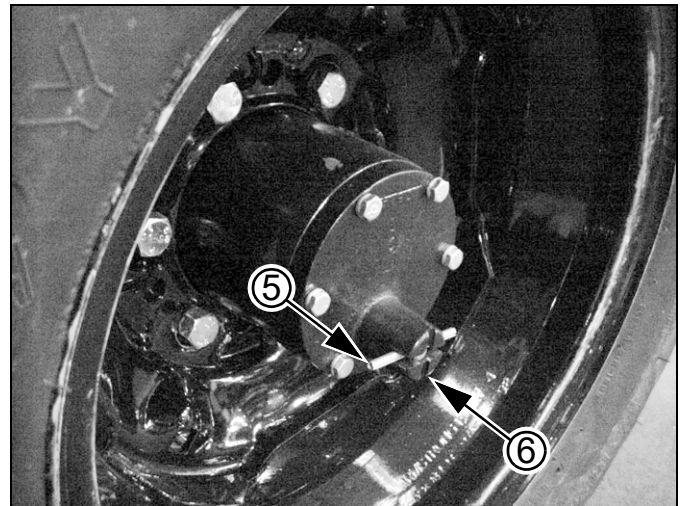

Figure 17
Lock-Out Hub Engaged

18480

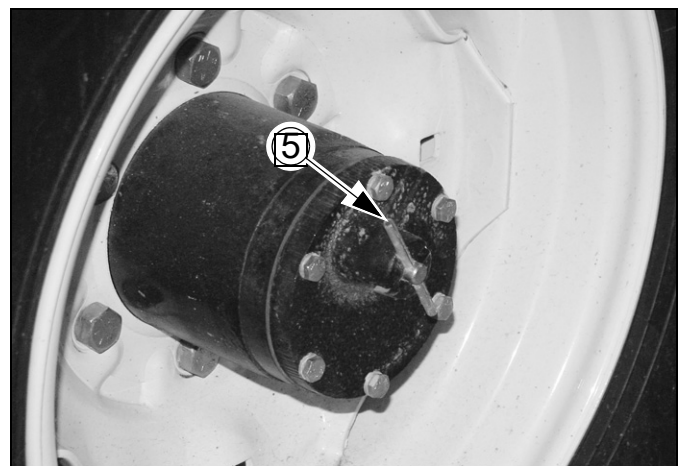

Figure 18
Lock-Out Hub Disengaged

27218

Transport Cautiously

Keep Clearance in Mind

Remember that the drill may be wider than the tractor. Allow safe clearance.

Observe Road Rules

Comply with all national, regional and local safety laws when traveling on public roads.

Reduce speed on rough roads.

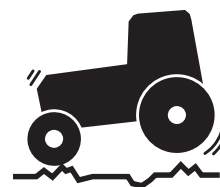

WARNING

Loss of Control Hazard:

Towing at high speeds or with a vehicle that is not heavy enough could lead to loss of vehicle control. Loss of vehicle control could lead to serious road accidents, injury and death. To reduce the hazard, do not exceed 20 mph (30 kph).

Loading Seed

WARNING

Possible Chemical Hazard:

Take all prescribed material safety precautions.

Fully loaded with dense seed, the drill weighs an additional 1155 lbs (529 kg). Include this weight when checking tractor capability.

The drill must be hitched for seed loading.

Load slightly more material than needed, because consumption rates can vary between compartments even though the furrow rates are identical.

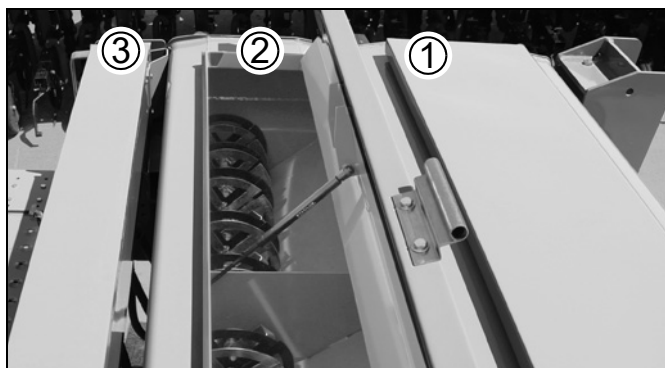

Figure 19
Native Grass Box Open

28362

① Main Seed Box Loading

1. Check that all meter doors are positioned for the seed size, and not set for clean-out. See **“Position Seed Cup Doors”** in seed Rate Manual. If loading prior to transport, set them to position 1 (smallest seed).
2. Install or remove optional seed plugs as desired for the row spacing planned. Refer to Seed Rate Manual.

If loading prior to transport, and calibration has not yet been done, set Seed Rate Handle to 0. At 0, and with the doors at 1, no seed can leak during transport.

3. The main seed box lid handle is also a latch. It needs to pivot up to release the lid.
4. Load seed evenly into compartments.

To reduce wear on unused boxes that may also be present:

- Remove final drive chain for Small Seed box.
- Remove any Native Grass chain.

② Loading Native Grass Box

1. The main seed box lid handle is also a latch. It needs to pivot up to release the lid.
2. Load seed evenly into compartments.
3. Add $\frac{1}{3}$ cup (80 mL) graphite seed lubricant on top of the loaded seed. In humid conditions, double or triple this amount as needed.

③ Loading Small Seeds Box

1. If loading prior to transport, and calibration has not yet been done, set Seed Rate Handle to 0. At 0, no seed can leak during transport.
2. Take all necessary materials safety precautions if the seed is treated.
3. The Small Seeds lid is held closed by two external rubber latches. Pull them up and to the rear to release the lid.
4. Load seed evenly into compartments.
5. To reduce wear, remove main shaft drive chains for main seed boxes.

Field Operation

1. Hitch drill to a suitable tractor (page 12).

For model 3P606NT, continue at step 5.

2. Raise drill. Hold at raised for several seconds to re-phase lift cylinders. Set circuit to Neutral. Shut off tractor.

Refer to Figure 16 page 20 and Figure 15 on page 20

3. Remove transport lock channels from cylinder rods. Move them to storage and re-pin. See page 20.

Refer to Figure 20

4. Engage drive with lock-out hub on the left gauge wheel. Pull pin ⑤ away from hub. Rotate 90°. Release into deeper notch pair.

Note: Pin may not seat fully immediately, but will at next drill movement.

5. Set seed population per rate chart and calibration, from Seed Rate manual.
6. Load box with clean seed.
7. Raise drill. Using calibration crank or 3-point gauge wheel, operate the meter drive system. Check that feed cups, seed tubes and drives are working properly and free from foreign material by looking for seed flow under each opener.
8. Lower drill. With a 3-point model, set hitch to Float.
9. Pull forward. Stop. Check tool bar height and opener depth.
10. Begin seeding.
11. Always lift drill out of the ground when turning at row ends and for other short-radius turns. Seeding stops automatically as drill is raised.

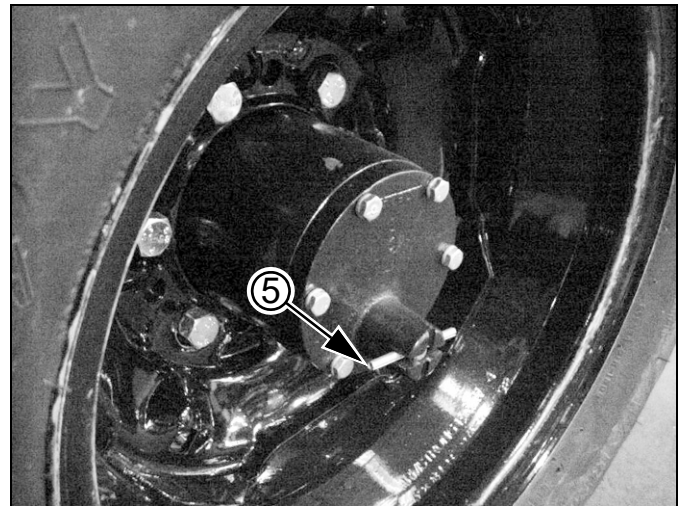

Figure 20
Lock-Out Hub Engaged

18480

Re-Phasing Cylinders

The lift cylinders may, after a period of time, get out of time or phase. The effects of this can be seen when one side of the drill is running too low or too high because its lift cylinder is either over extended or not retracted compared to the other lift cylinder.

To re-phase the cylinders, raise drill completely and hold tractor hydraulic lever on for a few seconds to give cylinders time to re-phase.

Each time drill is raised out of ground momentarily reverse hydraulic lever immediately after re-phasing to allow cylinders to retract about 1/2 in. (2.5 cm). This helps maintain a level drill.

Note: Having cylinders become gradually out of time is different than having air trapped in the system, a problem remedied by bleeding (page 46).

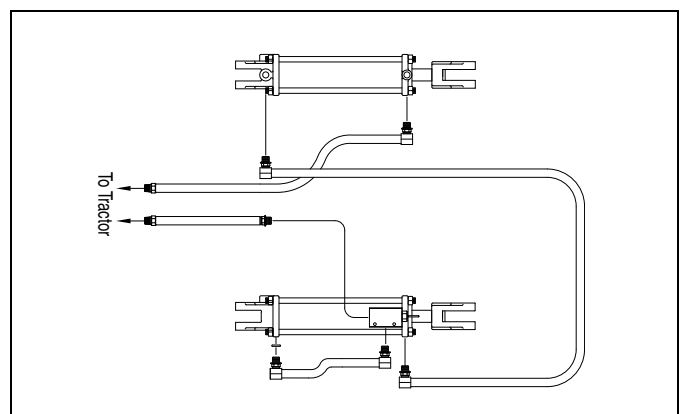

Figure 21
606NT Lift Hydraulics

18676

Parking

Perform the following steps when parking the drill for 36 hours or less. Refer to **“Remove hitch bolt and safety chain from tractor drawbar.”**, to prepare for long-term storage.

Parking Model 3P606NT

1. Park drill on a level, solid area.
2. Lower 3-point hitch until drill is on the ground.
3. Unplug wiring harness from tractor. Do not allow harness end to rest on the ground.
4. Extend or retract the top link of the tractor until top 3-point pin is free. Remove pin.
5. Remove pins from lower links.

Parking Model 606NT

1. Park drill on a level, solid area.
2. Lower drill until openers are resting on the ground.
3. Securely block tires to prevent rolling.

Refer to Figure 22 and Figure 23

4. Move jack to side stob near hitch. Re-pin as shown in Figure 23. If ground is soft, place a board or plate under jack.
5. Extend jack until tongue weight is off tractor drawbar.

Refer to Figure 24

(which depicts the hitch of a pull-type drill; the hose caddy and connector storage cap are similar on 3-point drills, if they have hydraulics)

6. Set tractor remote circuit for Lift to Float. Unplug hydraulic hoses. On newer drills, store the hose ends ① in the keyhole slots ② of the hose caddy ④.
7. Unplug wiring harness from tractor. On newer drills, insert the lighting connector ③ into the bottom of the connector cap ④. Rotate the plug as necessary until the keying tab ⑤ clears a mating cutout in the cap base, then rotate the plug 90°. Do not allow hose ends or cable ends to rest on the ground.
8. Remove hitch bolt and safety chain from tractor drawbar.

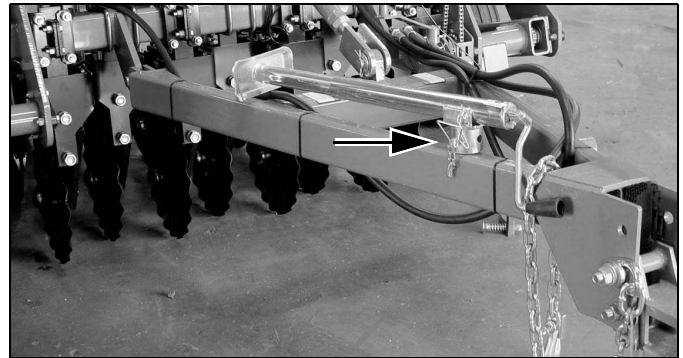

Figure 22
Parking Jack Storage

24481



Figure 23
Parking Jack Lowered

18473

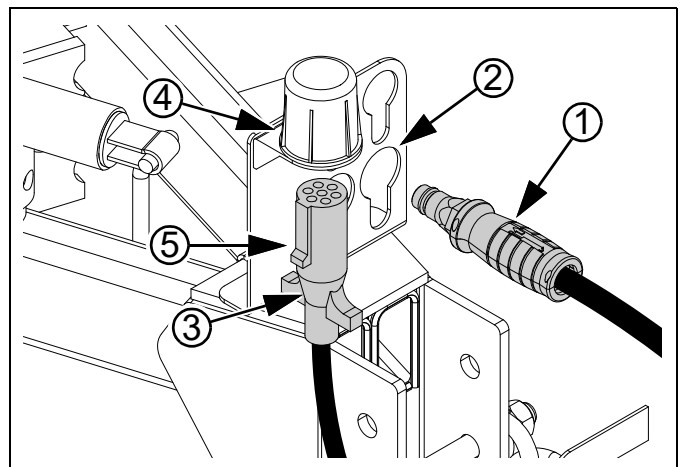

Figure 24
Hose and Connector Storage

36173

Acremeter Operation

A battery-operated electronic acremeter is supplied with the drill. The display module for the system is normally on the front face of the main toolbar near the left gauge wheel.



Acremeter Console 80377

The acremeter calculates and displays the field acres and total acres accumulated.

The meter counts rotations of the main ground drive shaft before the clutch. The meter tallies all movements with the drill unfolded, whether planting or not.

There are three buttons on the face of the acremeter:



Select - Navigates to the next screen. If the current screen has any settings, pressing the Select button will also save the current screen's settings.

Pressing Select while the screen is inactive will activate display mode starting on screen A1.



Up Arrow - Increments current value. If the current screen only displays a reading, then arrow buttons can be used to reset current reading or for navigation.



Down Arrow - Decrements current value. If the current screen only displays a reading, then arrow buttons can be used to reset current reading or for navigation.

Operating Instructions

The electronic acremeter operates in two modes: sleep and entry. In sleep mode, the display is blank, and the counter is accumulating acres. Sleep mode will be entered if a button is not pressed for 20 seconds. In entry mode, the display is on, and the operator can enter values.

To access entry mode, press and hold the SELECT button, the acre counter will cycle through the functions that it can perform. The available screens, in order, are:

- Field Acre Count
- Total Acre Count
- Battery Life
- Password
- Pulses per 400ft
- Swath Width
- Calibration
- Units of Measurement
- Sensor Count
- Change Password

Acrometer Screens

Field Acre Count

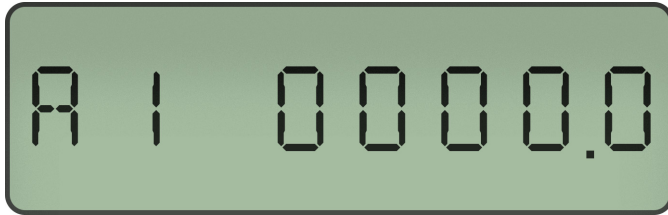

Displays the number of acres covered since the field acre counter was last reset. If there is an additional acre counting sensor on the machine, an A2 screen will immediately follow the A1 and T1 screens.

Pressing Select navigates to screen T1 or T2.

Press and hold both arrow buttons to reset the current field acre counter.

Total Acre Count



Displays the total number of acres covered since the total acre counter was last reset. If there is an additional acre counting sensor on the machine, a T2 screen will immediately follow the T1 and A2 screens.

Pressing Select navigates to screen BAT or A2.

Battery Life

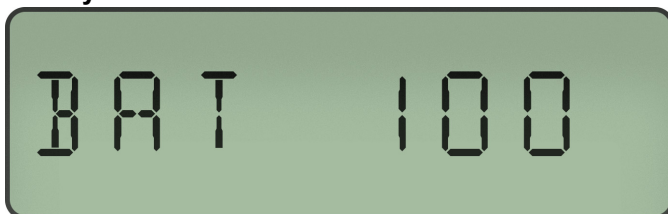

Displays the percentage of remaining battery life.

Pressing Select navigates to screen PW.

Password

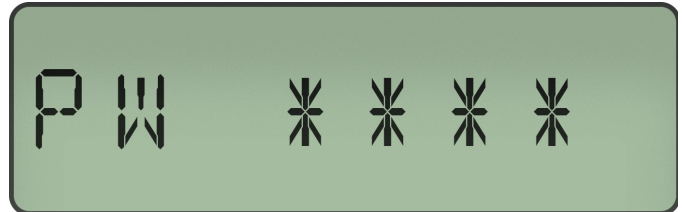

Displays the password screen. Entering your system password enables access to configuration parameters.

Use the arrow buttons to enter your 4 digit password.

Pressing Select while password is salted - **** - will navigate to the A1 screen.

Pressing Select while the correct password value is entered will navigate to the P1 screen. If the password is incorrect, the PW screen is reset.

Pulses Per Distance

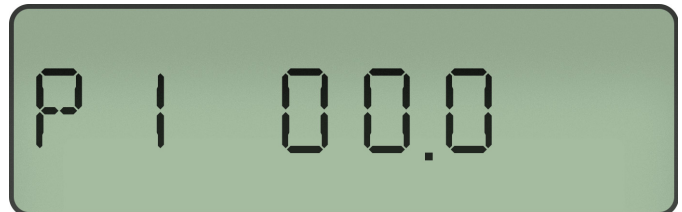

Displays the pulse scaling factor. This value affects the number of pulses emitted per 400ft traveled.

Use the arrow buttons to increase or decrease the scaling factor.

Pressing Select will save the configuration and navigate to the P2 or SW screen.

Swath Width

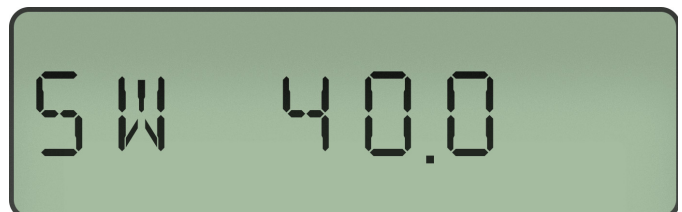

Displays the machine's swath width. To correctly calculate the number of acres planted, the acre meter needs the swath width of the drill.

Use the arrow buttons to increase or decrease the swath width.

Pressing Select will save the configuration and navigate to the CAL1 screen.

Calibration

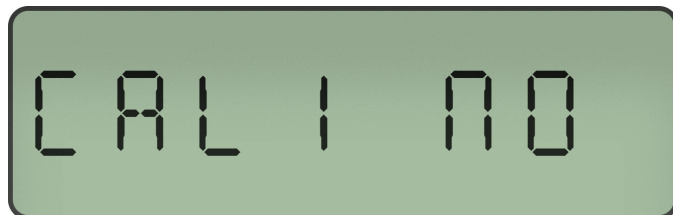

Displays either the calibration request status or the current calibration value.

If displaying the request status - YES or NO - and status is YES, pressing Select begins sensor calibration.

If displaying the request status and status is NO, pressing Select does not begin sensor calibration and instead navigates to the UNITS or CAL2 screen.

When calibrating and calibration value is greater than the acremeter's minimum required value, pressing Select saves the calibration value and navigates to the UNITS or CAL2 screen.

Units of Measurement

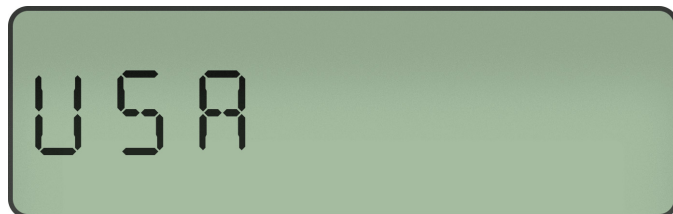

Displays the units of measurement used by the acre meter.

Use the arrow buttons to change the units of measurement to either USA - Imperial - or METRIC.

Pressing Select saves the unit selection, converts the swath width value, and navigates to the SENSOR screen.

Sensor Count



Displays the number of active sensors in the system.

Use the arrow buttons to change the entry value.

Pressing Select saves the sensor count configuration and navigates to the CHPW screen.

Change Password



Displays either the password change status or the new password value.

If displaying the change status - YES or NO -, use the arrow buttons to switch the change status.

If displaying a new password value, use the arrow buttons to increase or decrease the new password value. Holding the arrow buttons will automatically increase or decrease the password value.

If displaying the change status - YES or NO - and the status is YES, pressing Select allows for a new password to be entered.

If displaying the status and status is NO, pressing Select navigates to the A1 screen.

Storage

Store drill where children do not play. If possible, store the drill inside for longer life.

1. Unload seed boxes. Thoroughly clean seed-treatment residue from boxes and feed cups. See "**Seed Clean-Out**" on page 44.
2. Remove any dirt and debris that can hold moisture and cause corrosion.
3. Lubricate and adjust all roller chains.
4. Take special care to oil feed cup drive sprocket in its square bore.
5. Perform "**Lubrication and Scheduled Maintenance**" starting on page 48.
6. 606NT: Grease exposed cylinder rods.
7. Inspect drill for worn or damaged parts. Make repairs and service during the off season.
8. Use spray paint to cover scratches, chips and worn areas on the drill to protect the metal.
9. Disconnect seed hoses from openers. Permanent elongation and premature cracking of hoses may occur if stored connected. Plug hose ends to prevent pest entry into seed boxes.
10. Cover with a tarp if stored outside.

Adjustments

To get full performance from your drill, you need an understanding of all component operations, and many provide adjustments for optimal field results. Some of these have been covered earlier in this manual.

Even if your planting conditions rarely change, some items need periodic adjustment due to normal wear.

Planting Depth

Setting nominal planting depth, and achieving it consistently, is affected by multiple adjustable drill functions. From greatest to least effect they are:

- Opener depth (press wheel height)
- Coulter depth
- Opener down-pressure (spring)
- Opener frame down-force (optional weights)
- Row unit down-pressure spring
- Opener (tool bar) height
- Disc blade adjustments (as discs wear)

Seed Rates

Seeds are applied by fluted feed meters driven by the left end or center gauge wheel. Independent mechanisms control the rate for each box. Changing one rate does not affect the rate of other boxes.

Rate setting details are in Seed Rate manual 313-523B.

Main Box seed rate is controlled by adjustments for:

- Drive Type gearbox lever
- Rate handle at seed box (drill front)
- Feed Cup Door handle (one each seed tube)

Native Grass (Option) Seed rate is controlled by:

- Sprocket pairings at drill front
- Rate Reduction kit (if used)

Small Seeds (Option) rate is controlled by a Rate Handle (drill rear).

Adjustment	Page	The Adjustment Affects
Main Seed Box Rate		
Drive Type	SRM ^a	Coarse seed rate
Rate Adjustment Handle	SRM ^a	Fine seed rate
Seed Cup Doors	SRM ^a	Consistent seed metering
Native Grass Rate		
Sprocket Selection	SRM ^a	Fine seed rate
Seed Rate Reduction	SRM ^a	Coarse seed rate
Small Seeds Rate	SRM ^a	Fine seed rate
Frame Height	15	Compensate for unusual opener depths
Frame Level	15	Consistent seed depth
Frame Weight Adjustment	31	Consistent seed depths in challenging conditions
Coulter Depth	32	Furrow depth and consistent seed depth
Coulter Down-Force	33	Consistent furrow in challenging conditions
Drive Clutch Adjustment	33	Seeding only with openers in ground
06 Series Row Unit Adjustments		
Opener Spring	35	Consistent seed depths in challenging conditions
Disc Blade Adjustments	36	Compensate for disc wear
Disc Scraper Adjustment	44	Consistent seeding depth
Opener Depth (Press Wheel Height)	39	Primary control of seed depth
Press Wheel Selection	55	Furrow coverage behind seeding
Drive Idler Adjustment (606NT)	44	Consistent seed flow

- a. SRM: Seed Rate Manual: This adjustment is described in manual 313-523B.

Frame Weight Adjustment

In some challenging no-till conditions, the drill may not have enough weight to enable consistent coulters soil penetration. In such cases, additional weight may help.

An optional weight bracket kit is available. See page 58 for ordering information. The kit includes two brackets ①. The kit itself adds 180 pounds (82 kg) to the drill. It accepts up to 600 pounds (272 kg) of standard tractor weights (300 pounds on each bracket), for a maximum of 780 pounds (354 kg) additional weight.

See table at right for available down-force per coulters, with various drill and weight kit configurations.

⚠ CAUTION

Possible Transport Hazard:

Re-check that the tractor or towing vehicle is adequate for transport, particularly with a 3-point drill. Consider transporting without weights on the drill. A weight kit with maximum weights can increase empty drill weight by 34%.

NOTICE

Tractor Damage / Field Results Risks:

With weights installed, re-check that the tractor is adequate to pull the drill afield. A tractor that was marginal with the standard drill may provide inadequate performance with accessory weights.

Always install equal weight on each bracket. Unbalanced weights causes uneven furrow and seeding depth across the drill.

Note: The maximum number of tractor weights may vary by weight style and supplier.

After installing weights, re-check frame height and level (page 15), coulters depth (page 32) and opener disc depth (page 39).

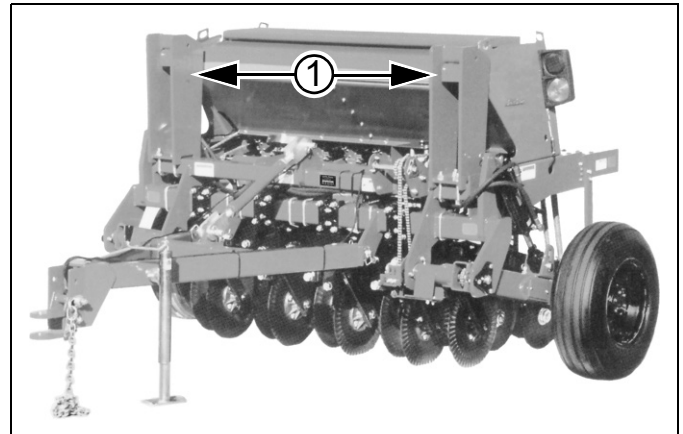

Figure 25
Accessory Weight Brackets

32703

Drill Configuration (no seed loaded)	Maximum Per Coulters	
	3P606NT	606NT
Standard Drill (no weight kit)	253 lbs 115 kg	294 lbs 133 kg
Standard Drill Kit, plus 300 Pounds	287 lbs 130 kg	328 lbs 149 kg
Standard Drill Kit, plus 600 Pounds	320 lbs 145 kg	361 lbs 164 kg
Drill w/ Small Seeds (SGS) Kit, plus 600 Pounds	337 lbs 153 kg	378 lbs 171 kg
Drill w/ Native Grass (NG) Kit, plus 600 Pounds	353 lbs 160 kg	394 lbs 179 kg
Drill with NG & SGS Kit, plus 600 Pounds	370 lbs 168 kg	405 lbs 184 kg

32774F

Coulter Adjustments

Refer to Figure 26

A no-till coulters ①, is mounted directly ahead of each opener on the drill. The coulters cut through heavy trash and make a groove in the soil for the openers.

The coulters are designed to operate with its spring ② at full extension. The spring is briefly compressed as the disc encounters and rides over difficult obstructions.

Coulter Depth

Land Pride recommends operating at a tool bar height of $24\frac{3}{4}$ in. (62.9 cm). Small adjustments may be required for unusual seeding depths and as coulters discs wear. If the coulters are not reaching desired depth (and the springs are uncompressed), the drill may need more weight (page 31).

Drill-wide coulters depth is controlled by tool bar height. The coulters are mounted on the drill frame. Group coulters cutting depth changes as the drill height is raised and lowered.

Note: When the opener frames are running level, the opener disc depth is $\frac{1}{4}$ in. (6 mm) above coulters depth.

Tool bar height is set by the tractor hitch for 3-point drills, and by cylinder depth stop (page 16) for pull-type drills. Individual Coulter Depth

Refer to Figure 26 and Figure 27

Individual coulters depth may be adjusted by raising and lowering the spring bar ③.

1. Determine the new coulters depth desired, and/or the difference between that and the current depth.
2. Raise the drill until the coulters discs are just touching the ground. The press wheels are supporting some row unit weight at this point.
3. Measure the current spring bar length ⑤, from bottom of tool bar to bottom of spring bar. For reference, the factory setting is:
⑤ $12\pm\frac{1}{8}$ in. (30.5±3 mm)
Determine the new bar length required.
4. Loosen the clamp bolts ⑥. Use a mallet to adjust the bar height. Re-tighten the clamp bolts to Grade 5 torque specification.

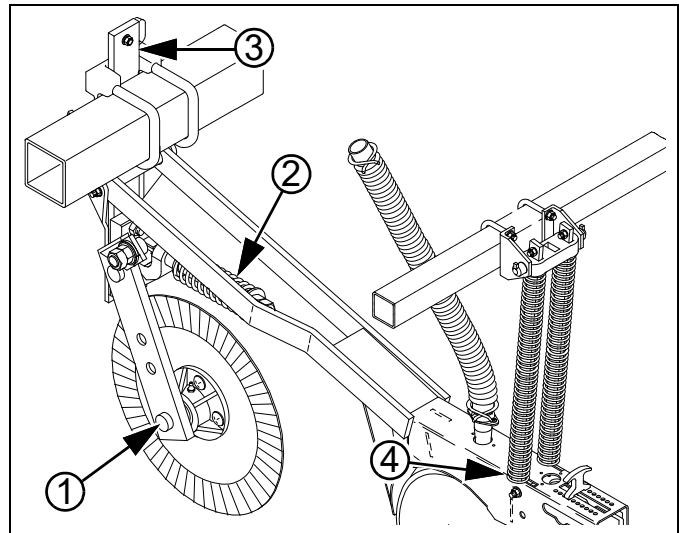

Figure 26
Frame-Mounted Coulter

18645

NOTICE

Seeding Depth Risk:

When adjusting coulters height, also reset opener spring force (page 35). Changing the coulters height changes the distance between row unit and spring attachment.

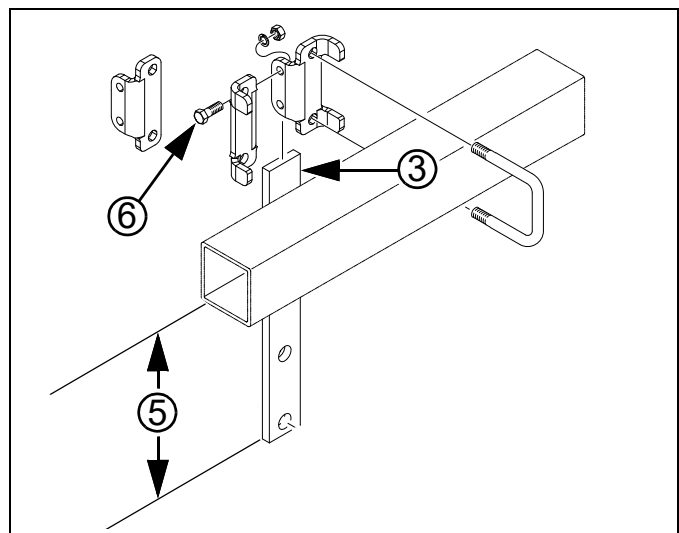

Figure 27
Coulter Spring Bar

32612

Coulter Down-Force

Refer to Figure 28

Coulter springs ② are preset at:
10 in. (25.4 cm)

giving coulters an initial maximum operating force of 400 pounds (181 kg). This setting is adequate for many difficult no-till conditions.

NOTICE

Machine Damage Risk:

Resetting coulters to a spring length shorter than 9³/₄ in. (24.8 cm) inches may contribute to a premature failure of parts not covered by warranty. If additional force is needed, add weights to drill (page 31).

For lighter no-till conditions where rocks or other obstructions are a problem, you can lengthen coulters to protect coulters from impact. Refer to table at right.

1. Measure current spring length.
2. Loosen or remove jam nut ⑦.
3. Rotate adjust nut ⑧ to set spring length.
4. Tighten set jam nut.

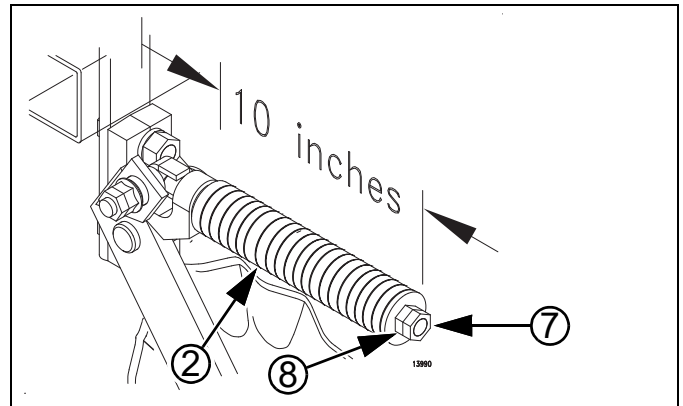

Figure 28
Coulter Spring Length

13990

Spring Length		Initial Vertical Coulter Force	
Inches	mm	Pounds	Kilograms
10 1/2 in.	267 mm	175 lbs.	79 kg
10 1/4 in.	260 mm	300 lbs.	136 kg
(f) 10 in.	254 mm	400 lbs.	181 kg
9 3/4 in.	248 mm	525 lbs.	238 kg

f. Factory setting.

32774J

Drive Clutch Adjustment

(Model 606NT only)

Refer to Figure 29

The main drive clutch ① on a pull-type drill is a mechanical-release, jaw-style design. You may need to adjust the clutch for proper engagement and disengagement.

When properly adjusted, the cam plates disengage the clutch jaws completely when the drill is raised. When lowered in field position, clutch jaws should be engaged.

To adjust, loosen bolts ② on clutch tab ③. Slide tab up or down to change point at which cam plates meet. When satisfied with adjustment, retighten bolts on clutch tab.

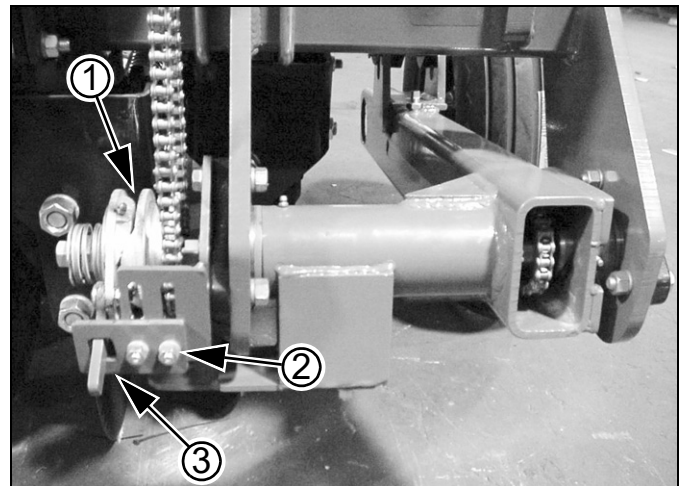

Figure 29
Drive Clutch

18482

06 Series Row Unit Adjustments

Refer to Figure 28 (which depicts an 06 Series row unit populated with most optional accessories)

From front to back, an 06 Series row unit (opener) can include the following capabilities (some optional):

1. **Coulter** (standard)
This is not part of the opener, but is co-mounted with it on the tool bar. See “**Coulter Adjustments**” on page 32.
2. **Opener Discs** (standard)
Row-unit double disc openers create the seedbed furrow. They have adjustments for spacing. See “**Disc Blade Adjustments**” on page 36.
3. **Main Seed Hose** (standard)
Seed released by the metering cups is gravity fed by the hose to the seed tube (not shown) between the opener discs. The hose and seed tube require no adjustments.
4. **Down-Pressure Springs** (standard)
Two springs per row provide the primary force on the opener discs. The spring setting may need adjustment for challenging soil conditions and/or for changes in coulter depth. See “**Opener Spring**” on page 35
5. **Inside Scraper** (standard)
This feature helps prevent soil buildup on the inside surfaces of the opener discs, allowing them to meet sharply and prepare a crisp seed furrow. See “**Disc Scraper Adjustment**” on page 37.
6. **Seed Firmer** (seed flap standard)
A seed firmer confines seed bounce and can press the seed into the furrow. The standard seed flap requires¹ no adjustments. See “**Seed Flap Replacement**” on page 45. Optional Keeton® or Seed-Lok® firmers do have adjustments. See “**Seed Firmer Adjustments**” on page 38.
7. **Option Seed Hose(s)** (optional)
If Native Grass or Small Seeds options are installed, there will be one or two additional seed hoses at or aft of the springs. The Small Seeds tube may be reversed if desired. See “**Seed Firmer Adjustments**” on page 38.
8. **Press Wheel Height** (standard)
The T-handle is primary control for seeding depth. See “**Opener Depth (Press Wheel Height)**” on page 39. The press wheels have no other adjustments, but a choice of press wheel styles and sizes is available. Consult your dealer.

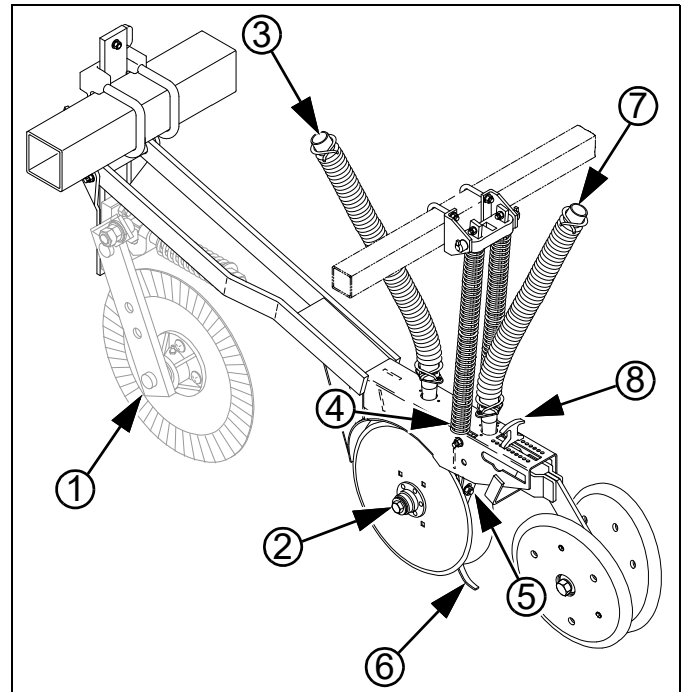

Figure 30
06 Series Row Unit

32720

NOTICE

Machine Damage Risk:

Never back up with row units on or in the ground. Seed tubes will plug or be seriously damaged. Raise the drill for all reverse and short radius turns, and when stopping while facing up hill.

1. The seed flap may need to be shortened in length if an optional Keeton® or Seed-Lok® firmer is installed.

Opener Spring

Opener springs provide the down pressure necessary for opener discs to open a seed trench. The springs allow the openers to float down into depressions and up over obstructions.

Each opener spring can be adjusted for down pressure. This is useful when planting in tractor tire tracks.

If coulter depth is altered for a row, the spring pre-compression needs to be changed to compensate for the change in row unit operating height.

Refer to Figure 31 and Figure 32

To adjust the pressure, remove "W" clip at bottom of spring. Place "W" clip in a higher hole in spring rod for more pressure or in a lower hole for less pressure.

Use this adjustment only for a few rows, typically in tire tracks.

Do not set row force higher on all rows. Instead use coulter adjustments (page 32) and frame weight adjustments (page 31).

Re-check drill level (page 15) after adjusting row force.

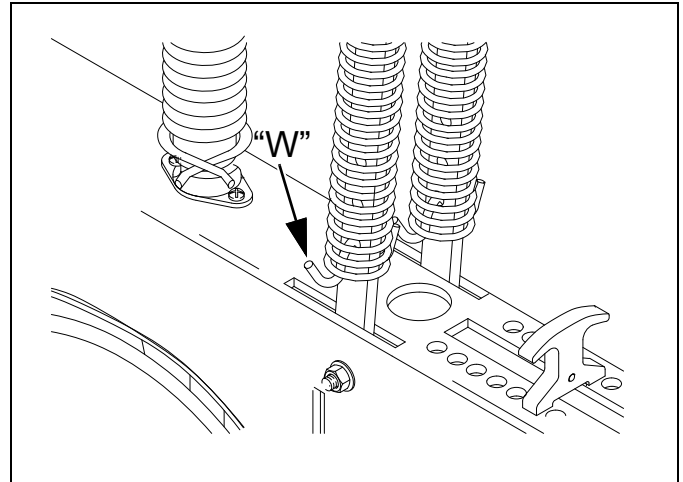

Figure 31
Minimum Force

12102

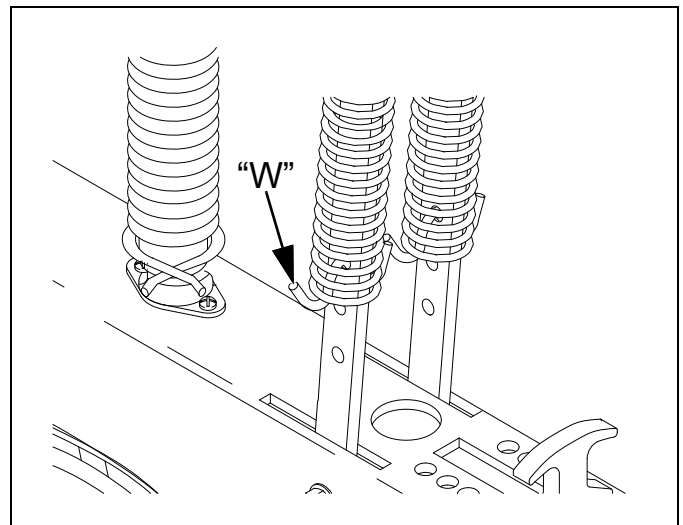

Figure 32
Maximum Force

12103

Disc Blade Adjustments

Raise drill and block it up or lock it up.

Opener Disc Spacing

CAUTION

Sharp Object Hazard:

Be careful working around and handling disc blades. Wear gloves. Edges of both new and well-worn blades can be sharp.

Opener disc angle and stagger is not adjustable, but disc-to-disc spacing is, and may need attention as discs experience normal wear. Spacers must be reset when blades are replaced.

Refer to Figure 33

The ideal spacing causes the blades to be in contact for about one inch. If you insert two pieces of paper between the blades, the gap between them should be 0 to 1.75 in. (0 to 4.4 cm)

If the blades do not touch, they should at least be close enough so that a business card encounters some friction when passing between them.

If the contact region is significantly larger or the gap too wide, it needs to be adjusted by moving one or more spacer washers. If the contact region varies with blade rotation, one or both blades is likely bent and in need of replacement. If removing all spacers cannot bring the blades into contact, they are worn out and need replacing.

Adjusting Disc Contact

Refer to Figure 34

1. Remove the bolt ① retaining the opener disc on one side. Carefully remove the disc, noting how many spacers ② are outside the disc and inside the disc. Do not lose the hub components and dust cap ③.

Note: It is not necessary to remove the hub flange or bearing for this adjustment.

2. To reduce the spacing between the discs (the normal case), move one spacer washer ① from the inside to the outside of the disc. It may be necessary to loosen the scraper (page 37) to reduce disc-to-disc spacing.
3. Re-assemble and check disc contact.
4. Re-adjust scraper.

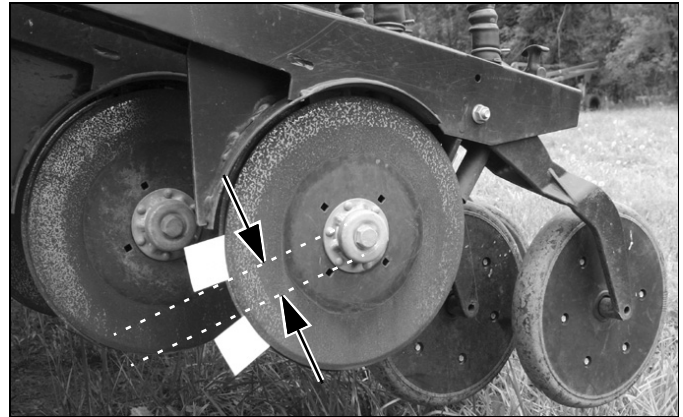

Figure 33
Checking Disc Contact

26451

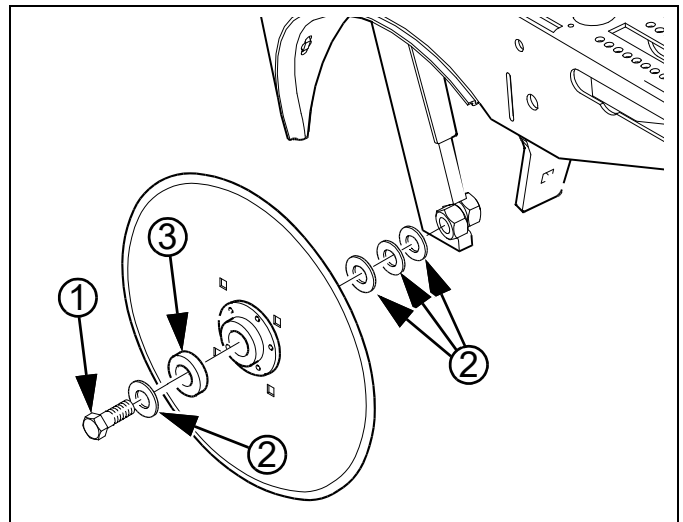

Figure 34
Adjusting Disc Spacers

26385

Disc Scraper Adjustment

To keep opener discs turning freely, dirt scrapers are mounted between discs to clean as the discs rotate. As field conditions vary, scrapers may need to be adjusted. In damp conditions, scrapers may need to be lowered. If openers are not turning freely, scrapers may need to be raised.

Re-adjust scrapers when replacing discs or adjusting disc spacing.

Refer to Figure 35

To adjust scrapers, loosen $\frac{3}{8}$ inch bolt ④ shown in and move scraper as needed.

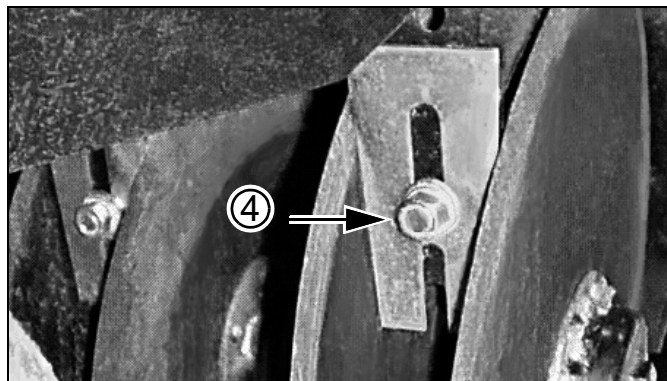

Figure 35
Disc Scraper Adjustment

18647

Seed Firmer Adjustments

Standard 05/06 Series row units include a seed flap. An optional Seed-Lok[®] or Keeton[®] seed firmer may be ordered separately.

The seed flap requires no adjustment, but may need to be replaced if worn, and may need to be shortened if an optional seed firmer is added after initial delivery. See also “**Seed Flap Replacement**” on page 45.

CAUTION

Sharp Object Hazard:

Use caution when making adjustments in this area. Row unit disc blades may be sharp. To adjust the Keeton[®] Seed Firmer, lower the drill until the discs of the row units are resting on the ground.

Seed-Lok[®] Lock-Up (Option)

Optional Seed-Lok[®] firming wheels provide additional seed-to-soil contact. The wheels are spring loaded and do not require adjusting. In some wet and sticky conditions the wheels may accumulate soil. To avoid problems associated with this, you can lock-up the firmers.

Refer to Figure 36 (shown with an opener disc removed for clarity - this task can be performed with discs mounted)

To lock up Seed-Lok[®] wheels:

1. Pull catch wire ⑤ aside.
2. Pull firming-wheel arm ⑥ up and release wire to catch arm.

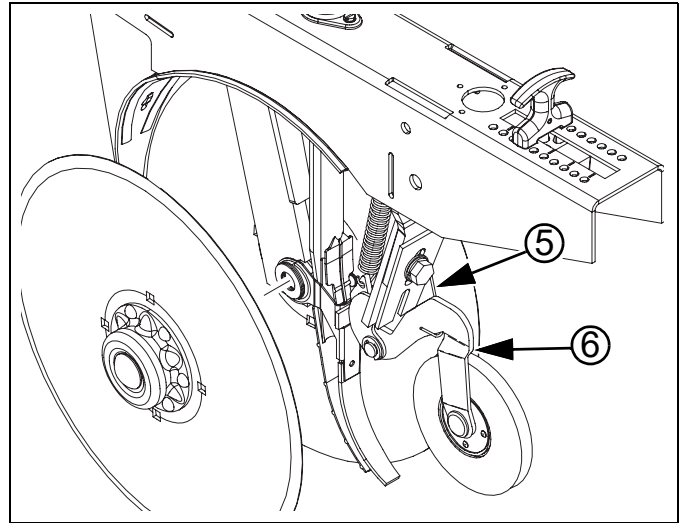

Figure 36
Seed-Lok[®] Lock-Up

27122

Keeton[®] Seed Firmer Adjustment (Option)

The optional Keeton[®] Seed Firmer is an engineered polymer shape that slides down the seed trench. It traps seeds as they exit the seed tube and firms them into the bottom of the furrow “V”.

Refer to Figure 37

The Firmer is provided with a preset tension which is recommended for using the first year. The tension screw ① can be tightened in subsequent years according to your needs. Firmers should provide just enough tension to push seeds to the bottom of the trench.

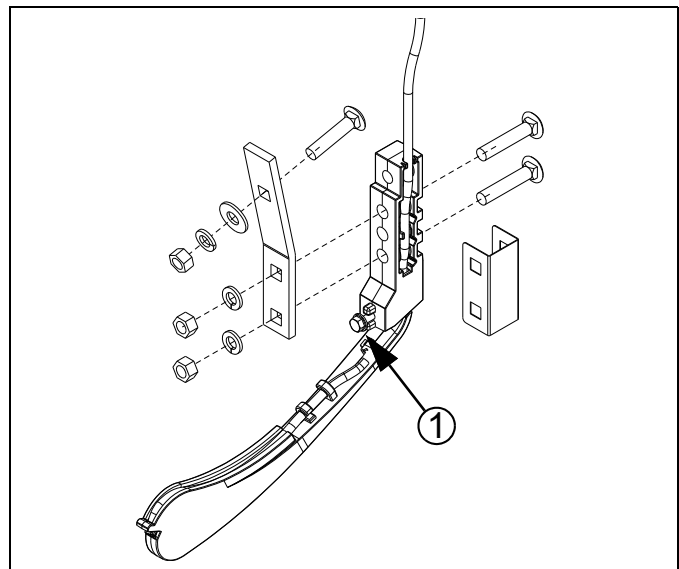

Figure 37
Keeton[®] Seed Firmer

26390

Small Seeds Tube Adjustment (Option)

Refer to Figure 38

On a drill with the Small Seeds option, deeper seed placement may be achieved by rotating the seed tube ① to face forward.

This orientation is suggested only if the seed firmer is a seed flap. If a Keeton® or Seed-Lok® is present, seed falls on the firmer and may be scattered rather than placed deeper.

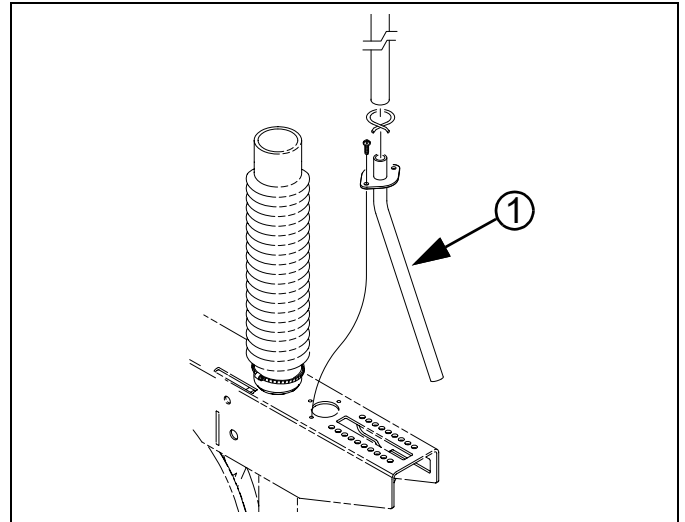

Figure 38
Small Seeds Tube

18618

Opener Depth (Press Wheel Height)

A press wheel attached to each opener body controls seeding depth ①. To maintain consistent depth, the relationship between the bottom of the opener discs and press wheel is fixed upwardly by an adjustable stop on each opener.

The press wheels also close the seed trench and gently press soil over seed. To provide consistent soil firming, press wheels are free to move down from normal operating position. This maintains pressing action even if opener discs encounter obstructions or hard soil.

To adjust, first raise openers slightly, then lift and slide T handles ② on top of openers. Adjust all press wheels to the same height.

- Each increment of the handle adjusts the seeding depth by approximately $\frac{1}{8}$ in. (6.3 mm). The range is approximately 0 to $3\frac{1}{2}$ in. (0-89 mm) seeding depth.
- For more shallow seeding, slide T handles forward ⑥ toward implement.
- For deeper seeding, slide T handles backward ⑦ away from implement.

If moving the T handle backward doesn't cause the opener to achieve desired depth, adjust the opener frame down-force (page 35).

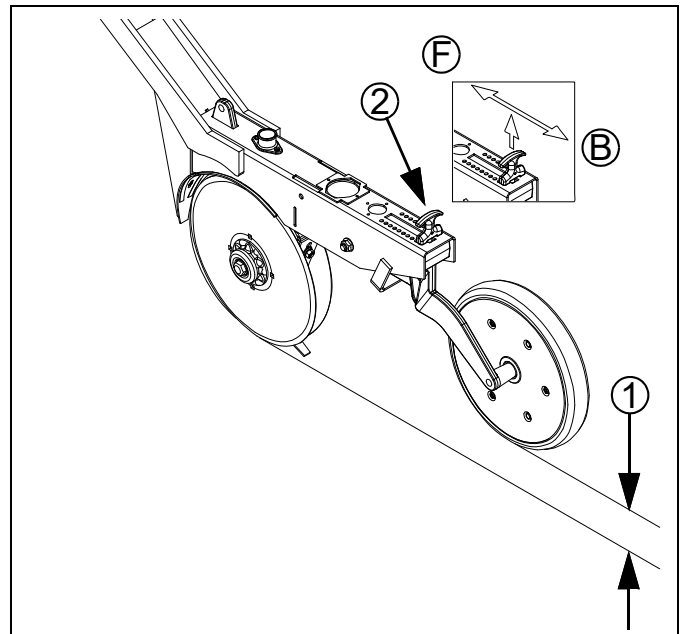

Figure 39
Adjusting Opener Depth

26441

Troubleshooting

Problem	Cause	Solution
Uneven seed spacing or uneven stand	Excessive field speed	Reduce field speed.
	Feed cups plugging	Clean out feed cups.
	Seed tubes plugging	Clean out seed tubes.
	Opener discs not turning freely	See “Opener discs not turning freely” in this Troubleshooting section.
	Opener not penetrating low spots	Adjust opener spring (page 35).
	Ground drive wheel slippage	Check frame height. Solution may require drier conditions.
	Seed cups too wide	Use faster Drive Type speed and close feed cup flutes to a more narrow position.
	Chain skipping	Check chain slack and wear.
	Mud build-up on Seed-Lok [®] wheel	Lock-up Seed-Lok [®] (page 38) or wait for drier conditions.
Uneven seed depth	Excessive field speed	Reduce field speed.
	Planting conditions too wet	Wait until drier weather.
	Drill not level	Readjust level (page 15).
Opener discs not turning freely	Trash or mud build up on disc scraper	Adjust scraper (page 37)
	Scraper adjusted too tight, restricting movement	Adjust scraper (page 37).
	Failed disc bearings	Replace disc bearings.
	Bent or twisted opener frame	Replace opener frame.
	Planting conditions too wet	Wait until drier weather.
	Too much opener down pressure	If opener discs turn freely by hand but not in field, reduce down pressure (page 35).
	Incorrect press wheel adjustment	Readjust press wheel (page 39).
Actual seed rate different than desired	Incorrect tire pressure	Check tire pressure (page 60).
	Incorrect frame height	Check frame height (page 15).
	Build up of seed treatment in feed cup	Clean out seed treatment from feed cups.
	Incorrect rate adjustment	Check gearbox, sprocket, seed-rate handle and seed door settings. Perform calibration if not already done. See Seed Rate Manual.

Problem	Cause	Solution
Excessive seed cracking	Excessive field speed	Reduce field speed.
	Feed cup flutes not open enough	Open feed cups to a wider position. See Seed Rate Manual.
	Feed cup door handle not open enough	Open feed cup door handle to a lower position. See Seed Rate Manual.
Press wheels not compacting soil as desired	Too wet or cloddy	Wait until drier weather or rework ground.
	Press wheel depth does not match coulter depth	Readjust press wheel depth (page 39).
	Not enough down pressure on disc openers	Increase down pressure on openers (page 35).
Boxes not emptying evenly	Some boxes do not have same number of feed cups between each divider of bulkhead.	Load more material than required. Re-distribute when re-loading.
	Main box seed cup door setting	Set all doors the same, per seed size.
	Seed plug(s) installed	Remove seed plug(s).
	Meter or tube blocked	Clear blockage.
Press wheel or openers plugging	Planting conditions too wet	Wait until drier weather.
	Too much down pressure on openers	Reduce down pressure on openers (page 35).
	Backed up with drill in the ground	Clean out and check for damage.
	Failed disc bearings	Replace disc bearings.
	Scraper worn or damaged	Replace scraper.
Feed cup sprockets locked up or twisted feed cup drive shaft	Foreign matter lodged in one or more feed cup sprockets	Clean out feed cup sprockets. Use clean seed.
	Dried liquid insecticide inside feed cups	Remove build up by disassembling each feed cup and scraping foreign substance from turn surfaces.
Coulters not going deep enough	Not enough down pressure	Adjust coulters when a few rows are involved (page 33). Add weight when all rows are affected (page 31).
	Row down pressure set too high (reducing weight available to coulters)	Reduce row down pressure to standard (page 35). Set coulters to prepare furrow more aggressively (page 32).
Coulters and drill going too deep	Coulters set too deep or spring force too high	See page 32 for correct adjustment.
	Incorrect press wheel adjustment	Set press wheels to a shallower depth.
Coulters and openers plugging in no-till conditions		Drill at a slight angle to rows.

Problem	Cause	Solution
Small seeds box not emptying evenly	Adjustable divider not set evenly	Move adjustable divider to create more volume in areas that run out first.
Chain fouling	Debris in retainer clip	Be sure retainer clip is facing opposite way of chain travel (page 47).
Acremeter inaccurate	Excess wheel slippage	Check frame height. If correct, solution may be to wait for drier conditions.
	Passes misaligned	Check that planting passes are not leaving gaps (under-reporting area) or causing overlap (over-reporting area).
	Wheel slippage is varying from nominal	If variance is consistent, develop a correction factor for your conditions.
	Check that acremeter is for your drill.	Activate display. Lower left corner must be: 3P606NT: 913.0 Revs/ac (2256.1 Revs/ha) 606NT: 995.0 Revs/ac (2458.7 Revs/ha) Contact dealer if otherwise.
	Acremeter battery failing	Replace acremeter (page 24). Unit is sealed and battery is not replaceable.

Maintenance and Lubrication

Maintenance

Proper servicing and maintenance is the key to long implement life. With careful and systematic inspection, you can avoid costly maintenance, downtime and repair.

Always turn off and remove the tractor key before making any adjustments or performing any maintenance.

⚠ WARNING

Crushing Hazard:

Always have frame sufficiently blocked up when working on, and particularly under implement. You may be severely injured or killed by being crushed under a falling implement.

⚠ WARNING

High Pressure Fluid Hazard:

Check all hydraulic lines and fittings before applying pressure. Use paper or cardboard, not body parts, and wear heavy gloves to check for suspected leaks. Escaping fluid under pressure can have sufficient pressure to penetrate the skin. Fluid escaping from a very small hole can be almost invisible. If an accident occurs, seek immediate medical attention from a physician familiar with this type of injury.

After using drill for several hours, check all bolts to be sure they are tight.

1. Securely block drill before working on it.
2. Lubricate areas listed under “**Lubrication and Scheduled Maintenance**” on page 48.
3. Clean any fittings that do not take grease.
4. Inflate tires as specified on “**Tire Pressures**” on page 60.
5. Inspect hydraulic hoses for cuts, cracks and aging. Check fittings for evidence of leaks.
6. Replace any worn, damaged or illegible safety decals. Order new decals from your Land Pride dealer. See “**Safety Decals**” on page 5.

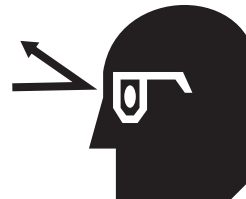
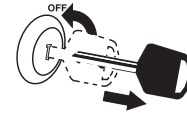

Drive Idler Adjustment (606NT)

Two idler sprockets are located inside the left hand gauge wheel arm. They should be readjusted after the first 100 acres (40 hectares) of drill use. From then on, readjust at the beginning of each season.

Refer to Figure 40

1. Loosen jam nut ①.
2. Move front idler sprocket on top of chain, tightening chain, by screwing in adjustment stud ②.
3. Retighten jam nut to maintain idler position.

Note: Do not over-tighten stud. Insufficient slack causes excessive wear and premature chain failure.

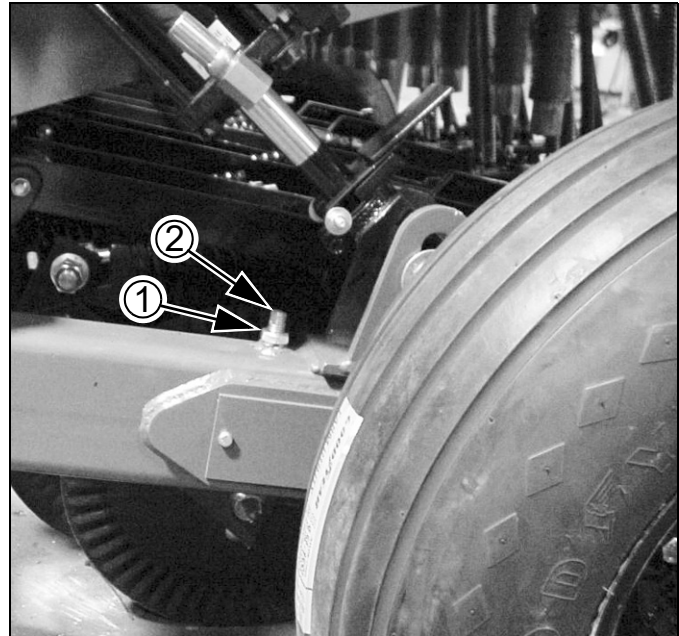

Figure 40
Gauge Wheel Idler Adjustment

18481

Seed Clean-Out

Main Box Clean-Out

Refer to Figure 41, which depicts the seed cup door handle ① in a normal operating position.

1. Set the Seed Rate Handle to zero (0). This moves the seed cup sprockets out of the seed path.
2. Position a tarp or bucket under each row or set of rows to be cleaned out.
3. At the seed cup for that row, pull the door handle ① out of the operating detent range, and swing it down to position ②.
4. Open the main seed box and use a small brush to sweep seed toward seed cups set to clean-out. If seed does not flow freely, inspect seed cup, hose and seed tubes for obstructions.
5. If a vacuum cleaner is available, use it to remove residual matter.

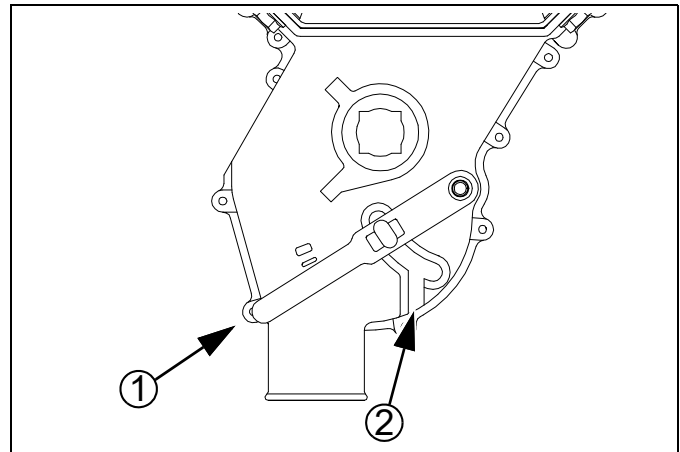

Figure 41
Seed Cup Clean-Out

26211

It is not necessary to operate the seed meter drive shaft for clean-out. With the Seed Rate set to zero, nothing moves inside the seed cups; however, an inspection of the flutes for excess wear and damage does require shaft rotation.

Set the Seed Rate Handle to 100. Raise and lock-up the drill. Turn the seed meter jackshaft with the calibration crank, while another person inspects the flutes from the open seed boxes.

Native Grass Box Clean-Out

If a suitable vacuum is available, open the Native Grass box lid, and vacuum out remaining seed.

If too much seed remains for the vacuum, or no vacuum is available:

1. Raise and lock up the drill. Place a tarp under the Native Grass seed tubes.
2. Set the Native Grass (right gearbox) Drive Type to 4. Optionally install the smallest final Driven sprocket.
3. Install the calibration crank, and turn the drive system until no seed flows from Native Grass tubes.
4. Vacuum out any residual material from above.

NOTICE

Machine Damage Risk:

Water wash-out is not recommended for the Native Grass box, particularly if seed lubricants have been used. Water may cause build-up of solidified residue. Filler material used in native grass mixes can also present problems.

Small Seeds Box Clean-Out

1. Open lid of each box and scoop out as much seed as possible.
2. To recover remaining seed, place a collection tarp under the small seeds tubes at the openers.
3. Raise drill.
4. Set seed rate handle to 100.
5. Rotate calibration crank or ground drive wheel until no seed flows.
6. If a vacuum cleaner is available, remove any residual seed from top of meters.

Seed Flap Replacement

Refer to Figure 43

To replace a seed flap ①, use needle nose pliers or similar tool to grasp "T" top of flap. Pull upward to remove flap from metal bracket ②.

Push new seed flap ① down through metal bracket ② until flap snaps into place with "T" top resting on top of bracket.

If a Seed-Lok® or Keeton® seed firmer is also installed, it may be necessary to shorten the flap.



Figure 42
Native Grass Box Open

28362

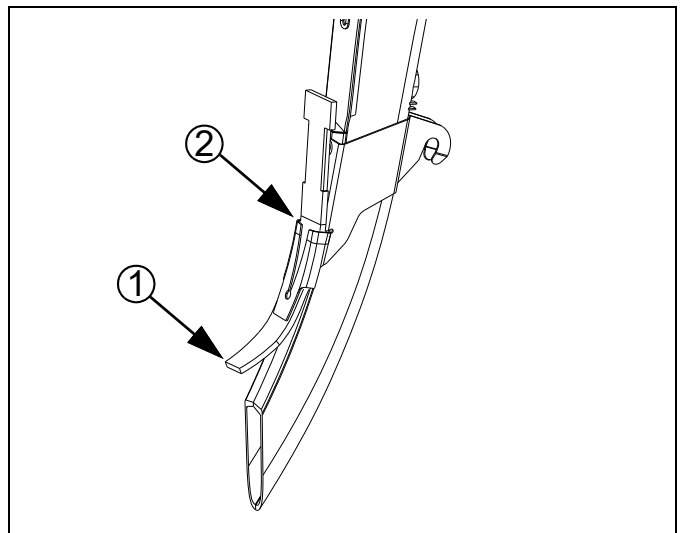

Figure 43
Seed Tube Flap

31047

Bleeding Hydraulics

Check that tractor hydraulic reservoir is full.

The drill lifting system is equipped with re-phasing type hydraulic cylinders that require a special procedure for bleeding air from the hydraulic circuits. Read and follow this procedure carefully. Re-phasing type cylinders will not function properly with air in hydraulic circuit.

1. Check hydraulic fluid in tractor reservoir and fill reservoir to proper level. Drill-system capacity is about 1 gallon (3.8 liters). Add fluid to system as needed. A low reservoir level may draw air back into the system, causing jerky or uneven cylinder movements.
2. With drill attached to tractor, jack drill up and support frame at ends near gauge wheels.
3. With drill raised and supported, un-pin cylinders at both gauge wheel arms and frame. Turn cylinders **rod end** up. Wire or otherwise safely support rod ends higher than base ends.
4. With tractor engine idling, engage tractor hydraulics to extend cylinder rods. When cylinder rods are completely extended, hold remote lever on for one minute.
5. Retract cylinders. Extend cylinders again and hold remote lever on for one more minute. Repeat this step two more times to completely bleed system.
6. Re-pin cylinders to drill frame and gauge wheel arm with transport cylinder locks in place. If any air still is trapped in either cylinder, the cylinder will have a spongy, erratic movement and drill will not raise evenly. If necessary, repeat bleeding process.
7. Refill tractor hydraulic fluid reservoir to its proper level.

WARNING

High Pressure Fluid Hazard:

Escaping fluid under pressure can have sufficient pressure to penetrate the skin. Check all hydraulic lines and fittings before applying pressure. Fluid escaping from a very small hole can be almost invisible. Use paper or cardboard, not body parts, and wear heavy gloves to check for suspected leaks. If an accident occurs, seek immediate medical assistance from a physician familiar with this type of injury.

Note: In order to prevent trapped air pockets, rod end must be higher than any other part of cylinder during bleeding operation.

Note: After the drill is raised, a slight settling will occur due to the action of the re-phasing cylinders.

Chain Maintenance

Initially check the drive chains after the first 10 hours of drill use. The slack of new chains tends to increase during the first few hours of operation due to seating. Thereafter, check the chains every 100 hours.

Lubricate chains any time there is a chance of moisture, and when being stored at the end of the planting season.

Chain Slack

Refer to Figure 44, which, for clarity, greatly exaggerates slack, and omits the idlers.

1. Measure the span ① for allowable slack:
Locate the longest span of each chain (usually the span which does not run through the idlers).
2. Determine the ideal slack:
Long chains (over 36 inches / 91 cm):
 $\frac{1}{4}$ in. per ft (21 mm/m)
Vertical short chains:
 $\frac{1}{4}$ in. per ft (21 mm/m)
Horizontal short chains:
 $\frac{1}{2}$ in. per foot (42 mm/m).
3. Measure the current slack ②:
Acting at a right angle to the chain span at the centre of the span, deflect the chain in both directions. The slack is the distance of the movement.
4. Adjust the idlers for ideal slack.

Whenever mounting a chain, make sure the clip at the removable link is oriented to minimize snags.

Refer to Figure 45 (arrow shows chain direction)

Install clip with open end facing away from direction of chain travel (shown by gray or striped arrows in chain routing diagrams).

Gearbox Maintenance

The gearbox is lubricated and sealed at the factory. Under normal conditions, it does not require maintenance or lubrication.

If the gearbox has been opened for repair, repack all gears and around shaft bearings using at least 7 oz. (200 mL) of gear lube, Great Plains Part No. 788067.

Keep moisture and dirt out of gearbox. Inspect (replace if needed) the rubber seals on gearbox drive and shifter shafts.

Spread a small skim coat of anaerobic sealant (Loctite[®] 525 or equivalent) to gear case mating surfaces before bolting them back together.

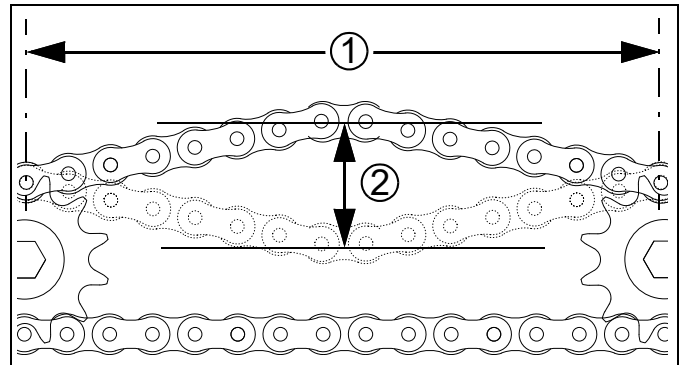

Figure 44
Measuring Chain Slack

27264

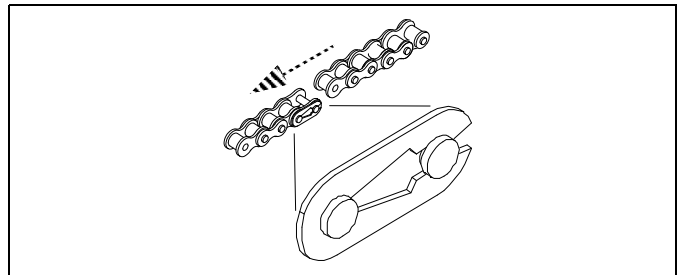
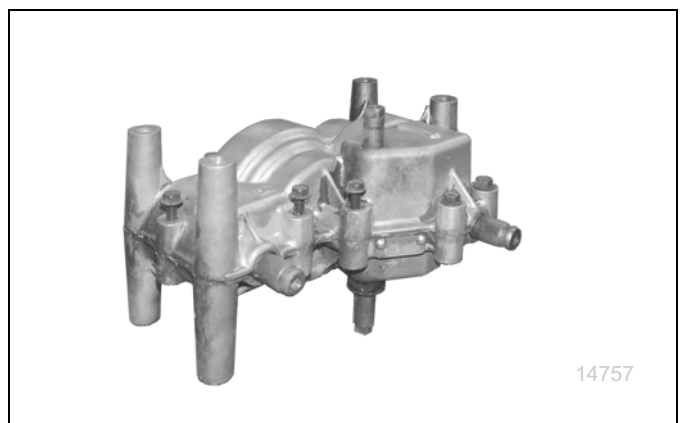

Figure 45
Chain Clip Orientation

26482







14757

NOTICE



Machine Damage Risk:

Use sealant sparingly. Excess sealant may squeeze off the intended surface and lock bearings or gears.

Lubrication and Scheduled Maintenance

 Multi-purpose spray lubricant	 Multi-purpose grease lubricant	 Multi-purpose oil lubricant	 Inspection	 Intervals (operating hours) at which service is required
---	--	---	---	--

Coulter Pivots

	 8
---	---

1 grease bank zerk per coulter;
9 total

Lubrication: Grease

Amount: until grease emerges at pivot



Drive Shaft Clutch

	 8
---	---

2 zerks total

Lubrication: bearing grease

Amount: until grease emerges

Note: Also smear grease on clutch engagement.

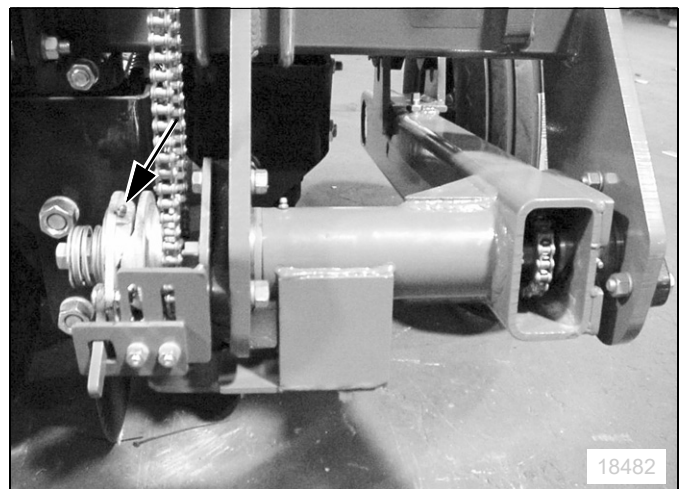

Seed Cup Drive Shaft Sprocket

	 10
---	--

1 sliding sprocket

Type of Lubrication: Oil

Quantity: Coat thoroughly

Move the Seed Rate adjustment handle back and forth to get oil into the square bore. Perform this with seed box empty, or handle may be difficult to set to 100.

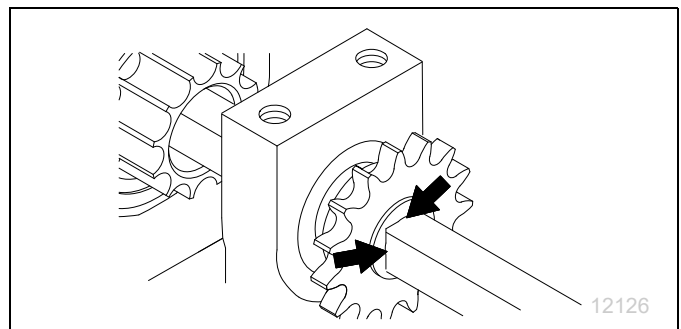

1. Loctite® is a registered trademark of Henkel Corporation.

Gauge Wheel Arms

		15
---	---	----

2 zerks each arm,
4 total

Type of Lubrication: Grease
Quantity: Until grease emerges

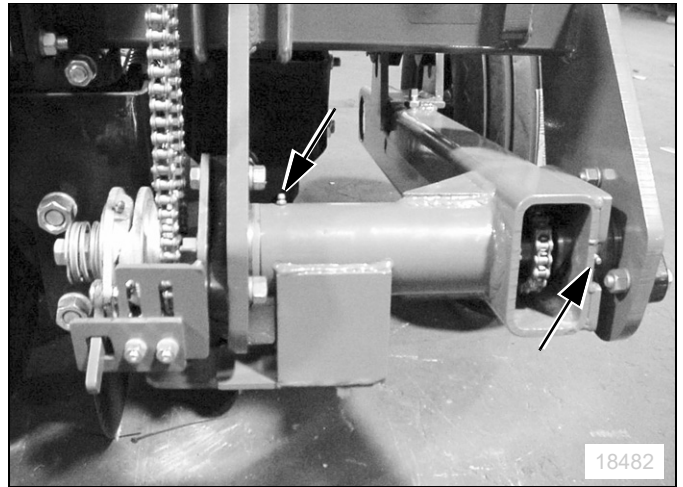

Small Seeds Shaft Bearings (Option)

		15
---	---	----

1 zerk total

Type of Lubrication: Grease
Quantity: Until grease emerges

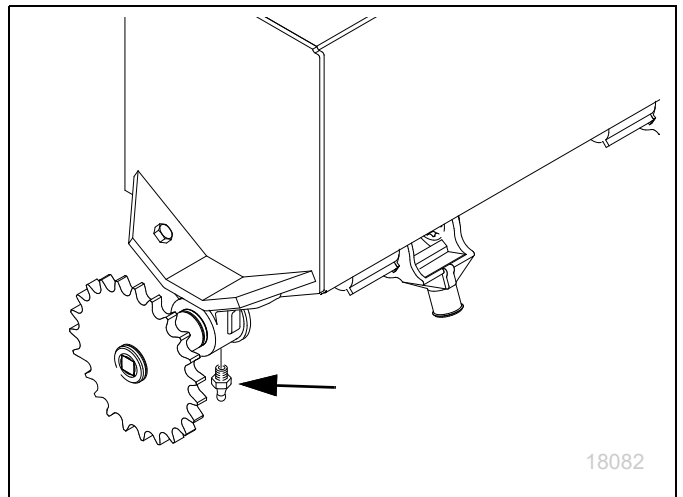

Drive Chains (Model: 3P606NT)



As Required

1 to 8 Chains Present:

Type of Lubrication: Chain Lube
Quantity: Coat thoroughly

Standard Chains

- drive wheel to front left jackshaft
- jackshaft to gearbox input
- gearbox output (right) to main seed cup shaft

Option Chains:

- gearbox output (left) to agitator/Native Grass (NG) jackshaft
- agitator/NG jackshaft to main box agitator and/or NG meter shaft
- gearbox input (right, pass-through) to Small Seeds (SGS) front right jackshaft
- SGS front right jackshaft to rear jackshaft
- SGS rear jackshaft to meter shaft drive

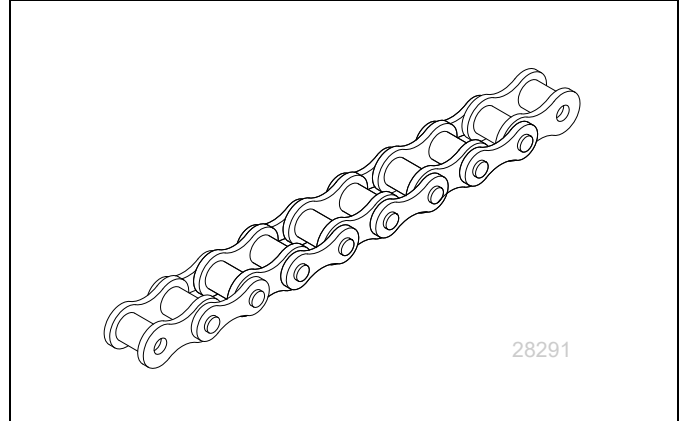

Drive Chains (Model: 606NT)



As Required

1 to 9 Chains Present:

Type of Lubrication: Chain Lube
Quantity: Coat thoroughly

Standard Chains

- drive wheel to clutch shaft
- clutch shaft to jackshaft
- jackshaft to gearbox input
- gearbox output (right) to main seed cup shaft

Option Chains:

- gearbox output (left) to agitator/Native Grass (NG) jackshaft
- agitator/NG jackshaft to main box agitator and/or NG meter shaft
- gearbox input (right, pass-through) to Small Seeds (SGS) front jackshaft
- SGS front jackshaft to rear jackshaft
- SGS rear jackshaft to meter shaft drive

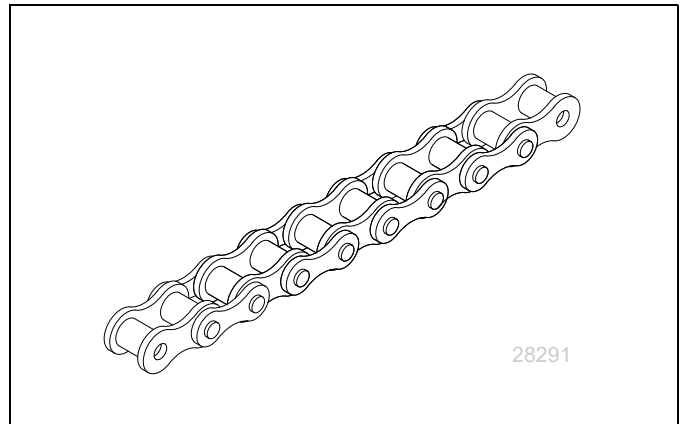

Coulter Hubs

		Seasonal
---	---	-----------------

1 zerk per coulter;
9 total

Type of Lubrication: Bearing grease
Quantity: Until resistance is felt

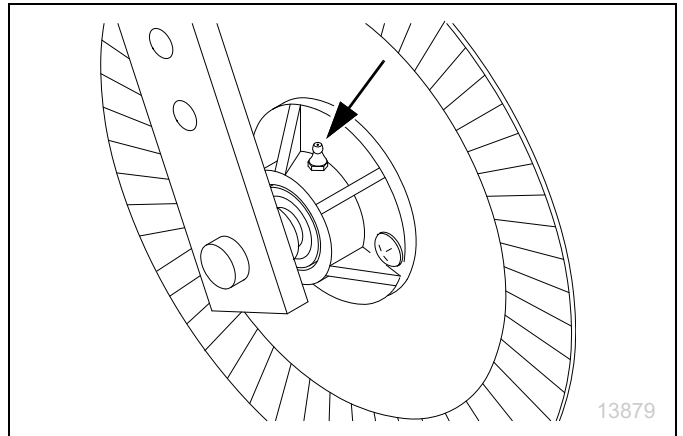

Wheel Bearings (3P606NT)

		Seasonal
---	---	-----------------

2 races total

Type of Lubrication: Bearing grease
Quantity: Re-pack

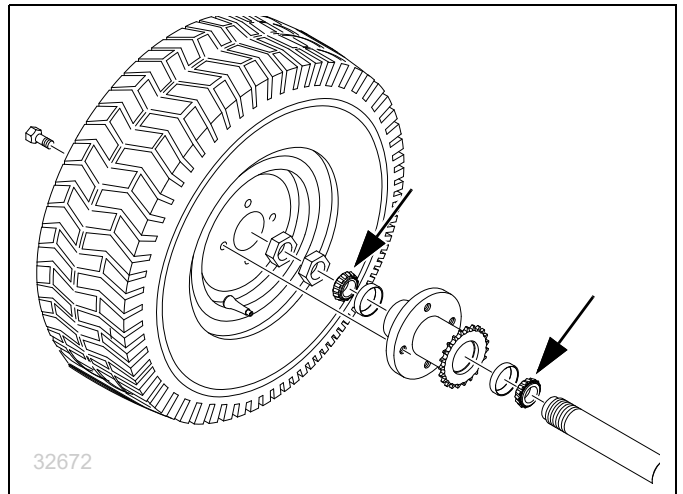

Left Wheel Bearings (606NT)



		Seasonal
---	---	-----------------

2 races total

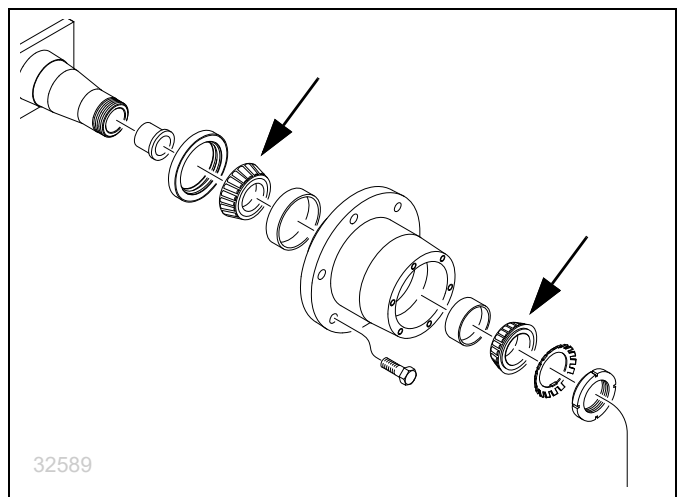
Type of Lubrication: Bearing grease
Quantity: Re-pack



Right Wheel Bearings (606NT)

		Seasonal
---	---	-----------------

2 races total

Type of Lubrication: Bearing grease

Quantity: Re-pack

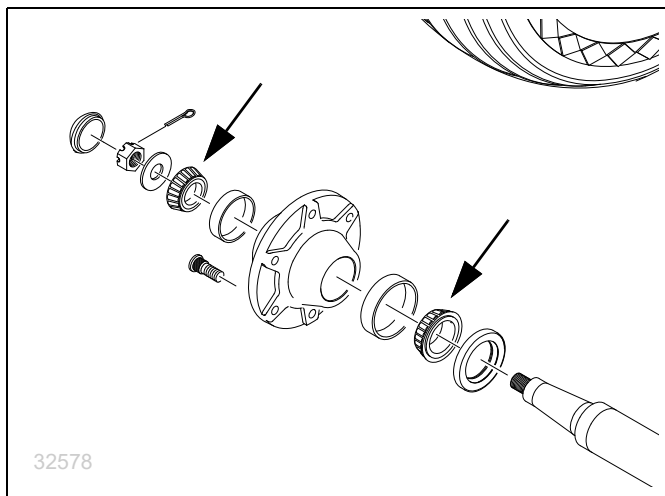

Options

Accessories are listed in alphabetical order. To order an accessory, contact your Land Pride dealer.

Alternate Acremeter

An electronic acremeter is standard on Model 3P606NT and 606NT. If you need a meter with an alternate units of measure, order one of the following parts.

Drill Model	Units	Part Number
3P606NT	acres	823-495C
3P606NT	hectares	823-495C
606NT	acres	823-495C
606NT	hectares	823-495C

See “**Acremeter Operation**” on page 24.



Carbide Disc Scraper

Slotted scrapers are standard.

Optional carbide disc scrapers are spring-loaded and require no periodic adjustment. Scrapers are compatible with the standard seed flap and Seed-Lok®, but not Keeton®.

Description	Part Number
SPRING SCRAPER ASSEMBLY	121-781A

See “**Carbide Disc Scraper Installation**” on page 70.

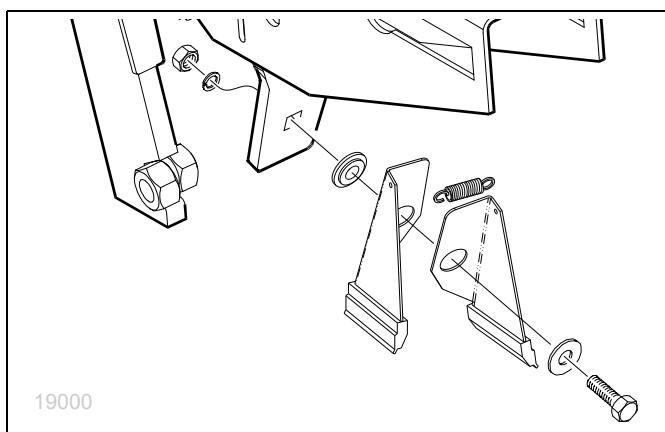

Coulter Blades

Replacement 17 in. (43 cm) blades are sold individually.

Description	Convolutions	Part Number
$\frac{5}{32}$ in. (40 mm) Fluted	50	820-018C
$\frac{3}{4}$ in. (2 cm) Wavy	24	820-082C
$\frac{5}{8}$ in. (1.5 cm) Wavy	24	820-116C
$\frac{5}{8}$ in. (1.5 cm) Wavy	20	820-156C

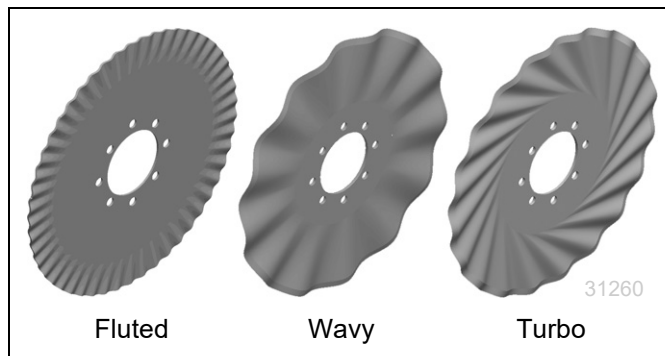

Hitches

A clevis or pintle hitch must be specified on the original order for a new 606NT drill. An alternative hitch is available as an accessory for conversion in the field.

Drill	Hitch	Option	Field Kit
606NT	Pintle	(81)	177-534A82
606NT	Clevis	(83)	177-536A82

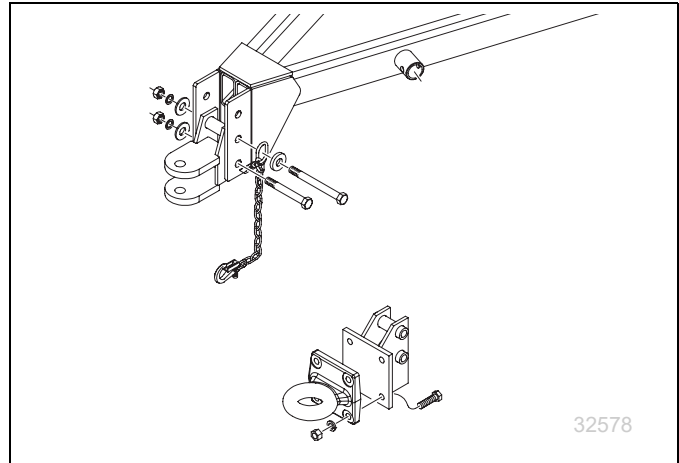

Main Seed Box Accessories

Agitator (Main Seed)

An optional agitator can be added to the main seed box.

It stirs the seed directly above the metering cups, helping prevent bridging of light, fluffy seeds and separating soybeans that are sticky with inoculant.

If your drill is also equipped with a Native Grass attachment, the agitator is available without a drive.

Description	Part Number
Agitator with drive (for drills without Native Grass)	118-750A
Agitator without drive (for drills with native Grass)	118-751A

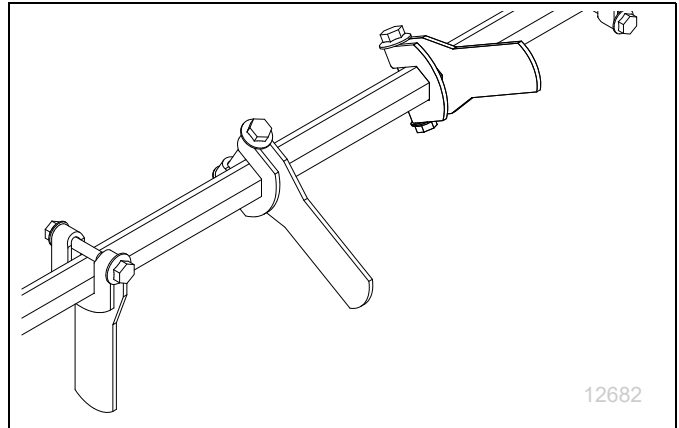

Seed Tube Plug (Main Seeds)

This plug stops seed flow from the main seed box above the meter. Order one per row to be set inactive.

Description	Part Number
Fluted Feed Meter Plug	817-087C

See "Main Seed Row Shutoff" in Seed Rate Manual.

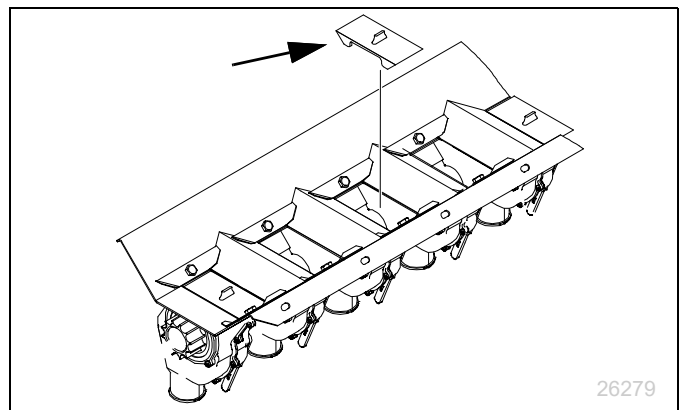

Series II Native Grass Attachment

The native grass attachment is designed to seed fluffy, hard-to-plant grasses. It is available as an Option on the original order (Option), or as a field-install kit when ordered with a field-installed Small Seeds Attachment (page 56).

Drill	Configuration	Option
3P606NT	Native Grass Only	(42)
3P606NT	Native Grass and Small Seeds	(43)
606NT	Native Grass Only	(42)
606NT	Native Grass and Small Seeds	(43)

See “**Loading Seed**” on page 22. For seed rates and adjustments, refer to “**Native Grass Attachment**” in the Seed Rate manual.

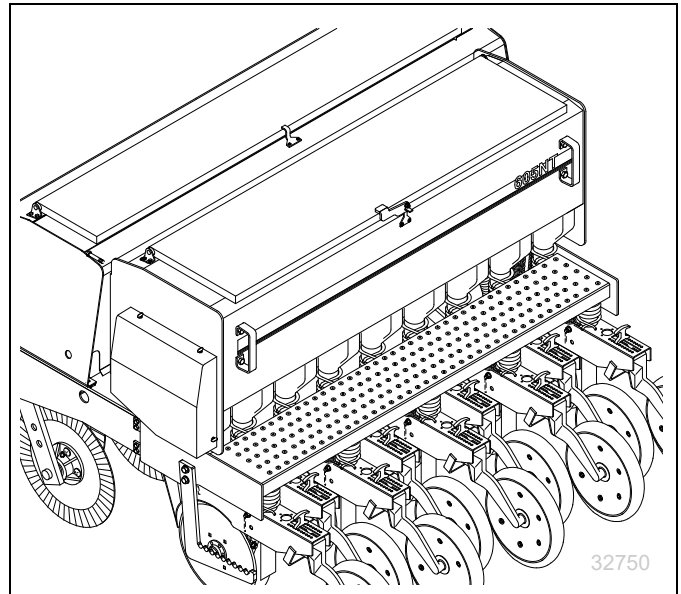

Seed Lubricants

Use seed lubricants only in Native Grass planting.

Description	Part Number
Graphite (1 lb / 0.45 kg bottle)	821-042C
Graphite (5 pound / 2.3 kg jug)	821-060C

See “**Loading Seed**” on page 22.



Null4:

Press Wheel Selection

The base drill includes a choice of press wheels. Additional wheels are available, and all may be field-installed.

This manual does not list kit part numbers as the available wheels are often region-specific. Consult your Land Pride dealer.

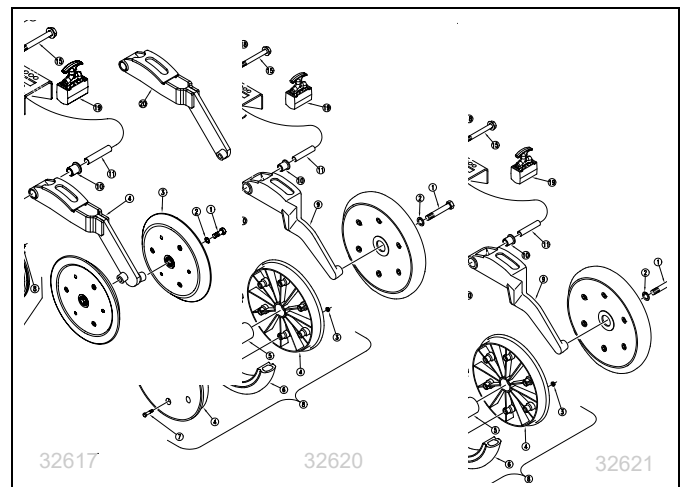

Small Seeds Attachment

The Small Seeds (SGS) attachment is designed to meter various small seeds in row. It is driven independently of other boxes on the drill. The standard attachment includes a drive system, 2.4 bushel box, meters and seed tubes.

Field upgrades to Small Seeds are available as:

Drill	Configuration	Opt.	Field Kit
3P606NT	SGS only, for a drill without Native Grass	(40)	133-131A82
3P606NT	SGS and NG	(43)	133-132A82
606NT	SGS only, for a drill without Native Grass	(40)	133-124A82
606NT	SGS and NG	(43)	133-125A82

For operation, see:

“**Loading Seed**” on page 22 and

“**Small Seeds Rate**” in Seed Rate Manual.



Small Seeds Tube Plug

This plug stops seed flow from the small seeds box above the meter. Order one per row to set inactive.

Description	Part Number
SML SDS CUP PLUG	133-315H

See Seed Rate Manual for use.

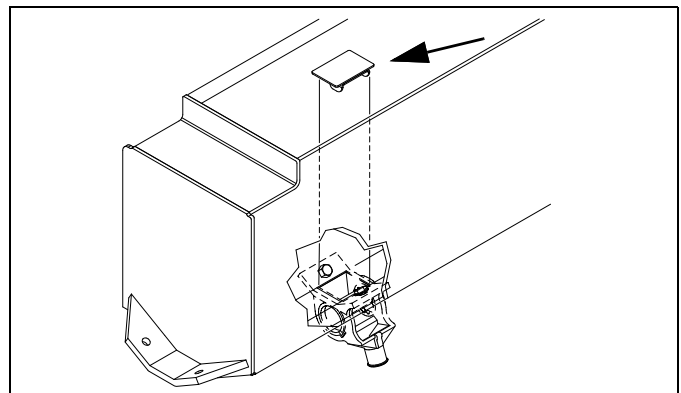

Small Seeds Partition

This partition reduces side-to-side seed flow in the small seeds box. This can prevent seed pile-up when drilling across slopes and in other situations where the seed is particularly fluid. Partitions are sold individually. Order quantity desired.

Description	Part Number
RMVBL SMALL SEED BOX PARTITION	123-409D

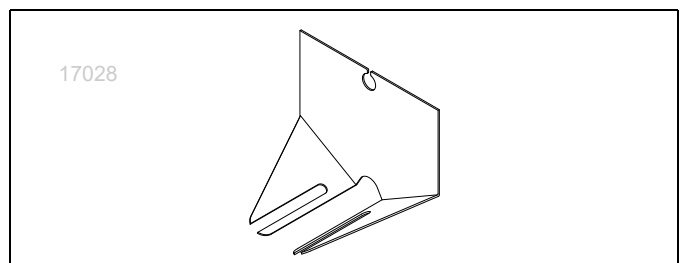

Seed Firmers

The standard drill includes seed flaps. A choice of firmers is an option in the product bundles, or may be field-installed as kits. Only one type of optional seed firmer may be installed at the same time. Order one firmer kit per opener.

Keeton® Seed Firmer

The optional Keeton® seed firmer is an engineered polymer shape that slides down the seed trench. It traps seeds as they exit the seed tube and firms them into the bottom of the furrow. Order one per row.

Description	Part Number
Keeton® Seed Firmer	890-810C

The Keeton® seed firmer supports low-rate fertilizer delivery. For this use, a liquid fertilizer system must also be installed on the tractor¹.

Seed-Lok® Seed Firmer

The spring-loaded Seed-Lok® firming wheel presses seed directly into the bottom of the seed bed. The Seed-Lok® option provides more even emergence since seeds are planted and firmed at the same depth.

Description	Part Number
Seed-Lok® kit	122-193K

Seed-Lok® can be used on all configurations except Native Grass, unless the Native Grass seed tube is removed during Seed-Lok® use.

For operations, see “**Seed-Lok® Lock-Up (Option)**” on page 38.

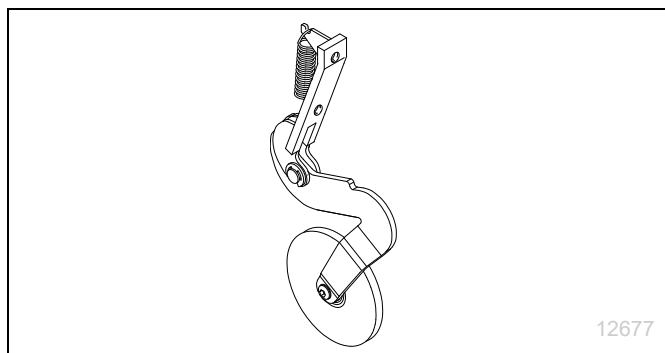
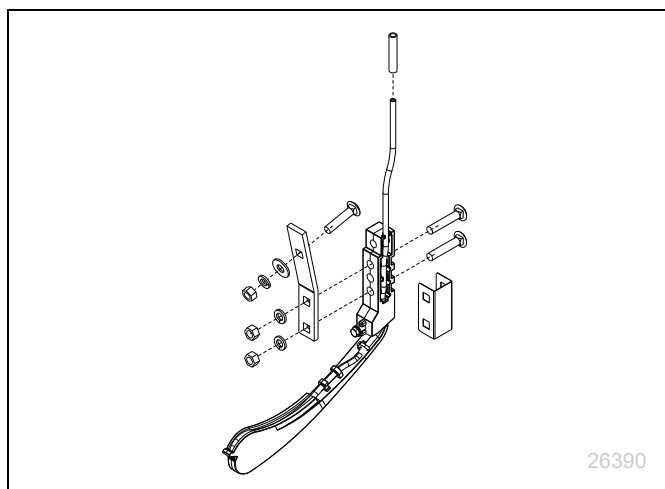

1. The Great Plains PFH accessory hitch is incompatible with the 3P606NT drill due to interference with the ground drive.

Weight Brackets

The weight brackets are available as Options on the original order, or as field-installed accessories. The weight brackets are available to add weight for additional penetration in no-till conditions. The kit includes two weight brackets two weight bracket adjustment legs, and mounting hardware. Also included are two decal mounts and two amber reflector decals (not shown).

Each weight bracket accepts up to five standard 100 pound (45 kg) "suitcase" style tractor weights.

The kits do not include weights.

Drill	Option	Field Kit
606NT	(66)	151-058A82
3P606NT	(66)	151-058A82

See the Transporting topic starting on page 18 and "**Frame Weight Adjustment**" on page 31. of "**Options**"

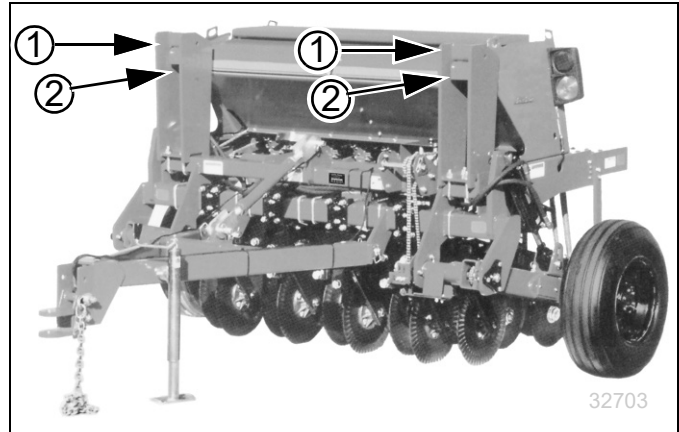

Appendix A - Reference Information

Specifications and Capacities

Drill Model	3P606NT820975	606NT820975
Row Count	9	9
Row Spacing	7.5 in. (19.1 cm)	7.5 in. (19.1 cm)
Swath	67.5 in. (171.5 cm)	67.5 in. (171.5 cm)
Transport Width	6 ft. 1/2 in. (72.5 in., 184.2 cm)	8 ft 10 in. (106.0 in., 269.2 cm)
Length	5 ft 1 in. (61.0 in., 154.9 cm)	11 ft 5 in. (137.0 in., 348.0 cm)
Working Height	5 ft 1 in. (61.0 in., 154.9 cm)	5 ft 1 in. (61.0 in., 154.9 cm)
Transport Clearance	Depends on tractor hitch	14.0 in. (35.6 cm)
Weight, Maximum, Empty ¹	2280 lbs. (1034 kg)	2700 lbs. (1225 kg)
Weight, Maximum, Full	4230 lbs. (1919 kg)	4600 lbs. (2087 kg)
Tongue Weight, Transport	NA	366 lb (166 kg)
Tongue Weight, Field	NA	416 lb (189 kg)
Main Seed Box Capacity	12 bu. (423 liter)	12 bu. (423 liter)
Native Grass Box Capacity	6 bu. (211 liter)	6 bu. (211 liter)
Small Seeds Box Capacity	1.44 bu. (51 liter)	1.44 bu. (51 liter)
Seed Box Agitator	Optional in Main Seed box, Standard in Native Grass box	
Min. Tractor HP Req. ²	60 hp (45 Kw)	40 hp (30 Kw)
Hitch Type	Category II	Clevis or Pintle
Hydraulic Circuits Req.	None	1
Tire Size	5.70L x 8 Lug Type	7.00-15 LT
Operating Depth	0 to 3.5 in. (0 to 8.9 cm)	0 to 3.5 in. (0 to 8.9 cm)

1. See "Transporting" topic for typical weights of various configurations.

2. Power requirements vary significantly with conditions and practices.









Tire Pressures

Tire Size	Inflation
Right-Hand Gauge Wheel 7.00-15 LT	60 psi 414 kPa

Tire Warranty Information
<p>All tires are warranted by the original manufacturer of the tire. Tire warranty information is found online at the manufacturer's websites listed below. For assistance or information, contact your nearest Authorized Farm Tire Retailer.</p> <p>ManufacturerWebsite Firestonewww.firestoneag.com Goodyearwww.goodyearag.com BKTwww.bkt-tires.com/en Titanwww.titan-intl.com Gleasonwww.gleasonwheel.com</p>

Torque Values Chart

Bolt Size in-tpi ^a	Bolt Head Identification					
	 Grade 2		 Grade 5		 Grade 8	
	N-m ^b	ft-lb ^d	N-m	ft-lb	N-m	ft-lb
1/4-20	7.4	5.6	11	8	16	12
1/4-28	8.5	6	13	10	18	14
5/16-18	15	11	24	17	33	25
5/16-24	17	13	26	19	37	27
3/8-16	27	20	42	31	59	44
3/8-24	31	22	47	35	67	49
7/16-14	43	32	67	49	95	70
7/16-20	49	36	75	55	105	78
1/2-13	66	49	105	76	145	105
1/2-20	75	55	115	85	165	120
9/16-12	95	70	150	110	210	155
9/16-18	105	79	165	120	235	170
5/8-11	130	97	205	150	285	210
5/8-18	150	110	230	170	325	240
3/4-10	235	170	360	265	510	375
3/4-16	260	190	405	295	570	420
7/8-9	225	165	585	430	820	605
7/8-14	250	185	640	475	905	670
1-8	340	250	875	645	1230	910
1-12	370	275	955	705	1350	995
1 1/8-7	480	355	1080	795	1750	1290
1 1/8-12	540	395	1210	890	1960	1440
1 1/4-7	680	500	1520	1120	2460	1820
1 1/4-12	750	555	1680	1240	2730	2010
1 3/8-6	890	655	1990	1470	3230	2380
1 3/8-12	1010	745	2270	1670	3680	2710
1 1/2-6	1180	870	2640	1950	4290	3160
1 1/2-12	1330	980	2970	2190	4820	3560

Bolt Size mm x pitch ^c	Bolt Head Identification					
	 Class 5.8		 Class 8.8		 Class 10.9	
	N-m	ft-lb	N-m	ft-lb	N-m	ft-lb
M 5 X 0.8	4	3	6	5	9	7
M 6 X 1	7	5	11	8	15	11
M 8 X 1.25	17	12	26	19	36	27
M 8 X 1	18	13	28	21	39	29
M10 X 1.5	33	24	52	39	72	53
M10 X 0.75	39	29	61	45	85	62
M12 X 1.75	58	42	91	67	125	93
M12 X 1.5	60	44	95	70	130	97
M12 X 1	90	66	105	77	145	105
M14 X 2	92	68	145	105	200	150
M14 X 1.5	99	73	155	115	215	160
M16 X 2	145	105	225	165	315	230
M16 X 1.5	155	115	240	180	335	245
M18 X 2.5	195	145	310	230	405	300
M18 X 1.5	220	165	350	260	485	355
M20 X 2.5	280	205	440	325	610	450
M20 X 1.5	310	230	650	480	900	665
M24 X 3	480	355	760	560	1050	780
M24 X 2	525	390	830	610	1150	845
M30 X 3.5	960	705	1510	1120	2100	1550
M30 X 2	1060	785	1680	1240	2320	1710
M36 X 3.5	1730	1270	2650	1950	3660	2700
M36 X 2	1880	1380	2960	2190	4100	3220

- a. in-tpi = nominal thread diameter in inches-threads per inch
- b. N·m = newton-meters
- c. mm x pitch = nominal thread diameter in mm x thread pitch
- d. ft-lb = foot pounds

Torque tolerance + 0%, -15% of torquing values. Unless otherwise specified use torque values listed above.

25199

Hydraulic Diagram

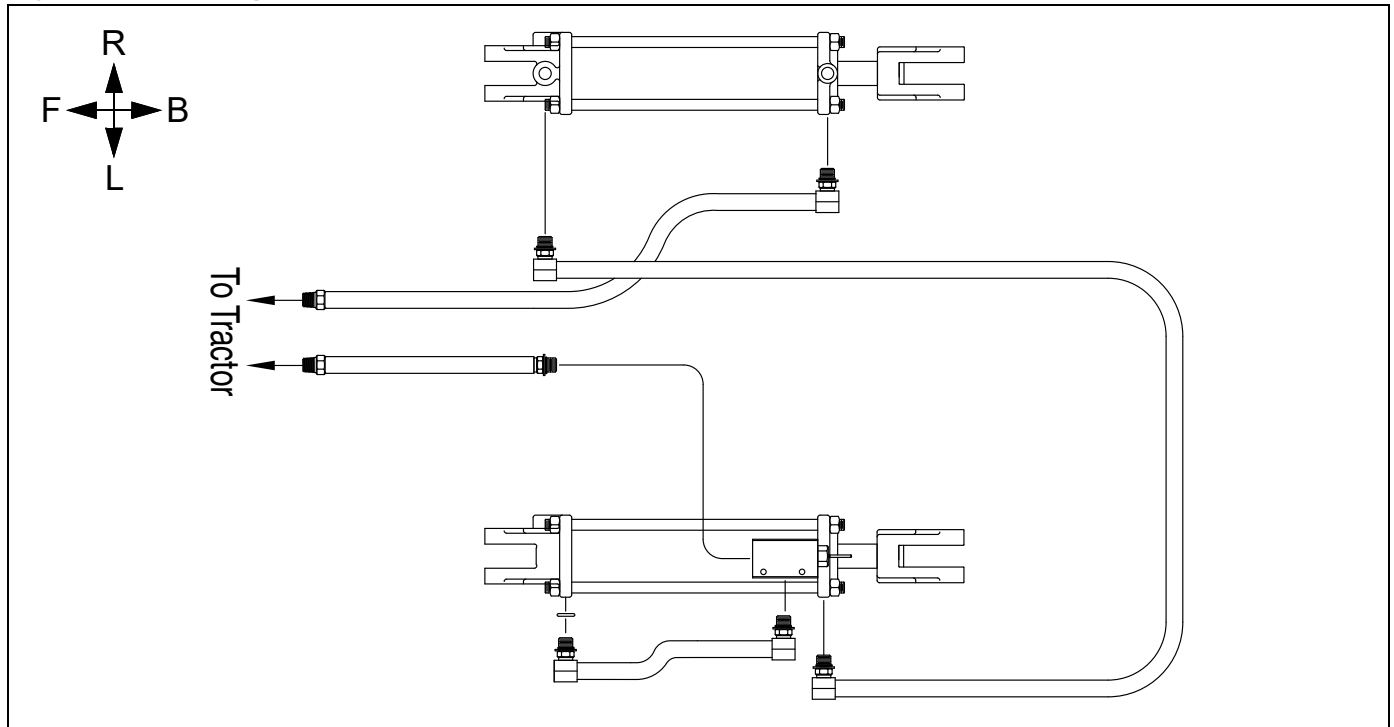

Figure 46
606NT Hydraulic Diagram

18676

Drive System Diagrams

3P606NT Drives

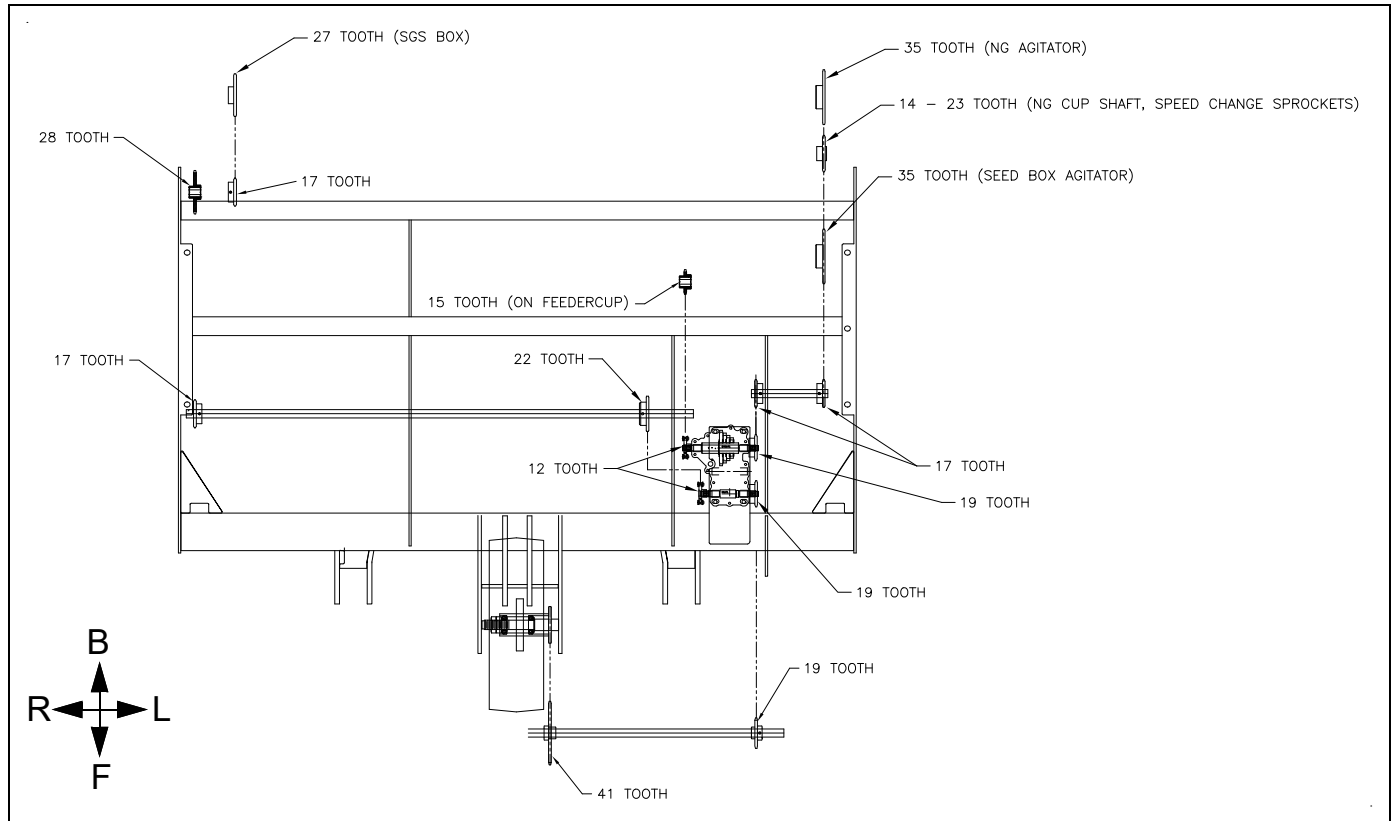

Figure 47
3P606NT Maximum Configuration

23213

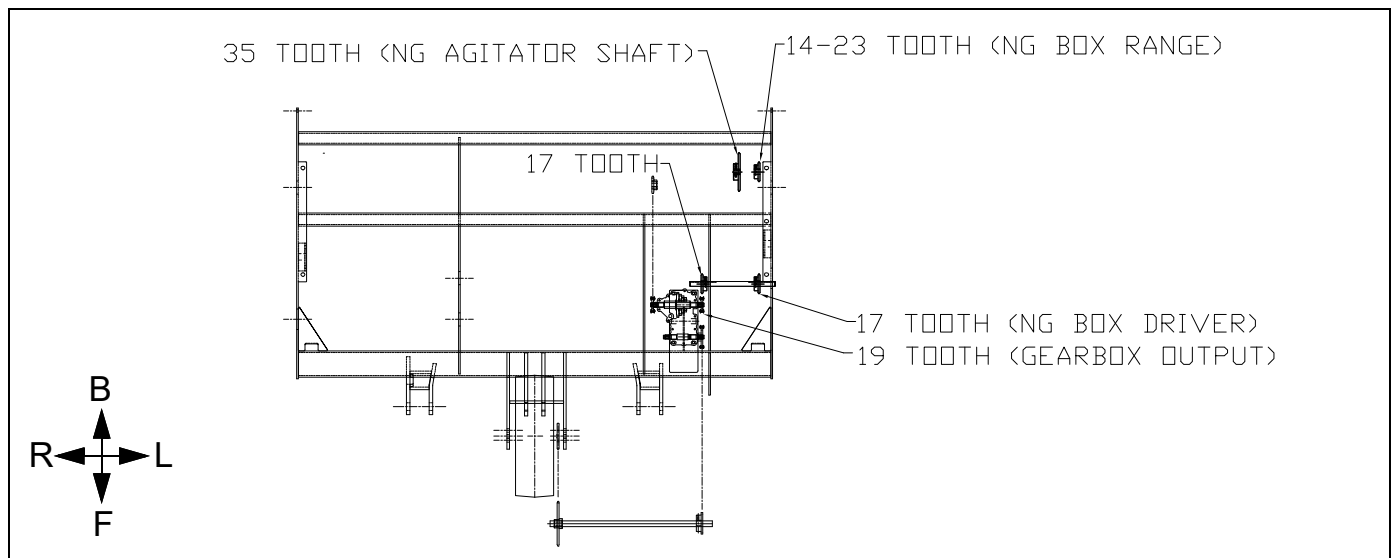

Figure 48
3P606NT Native Grass (Option)

23110

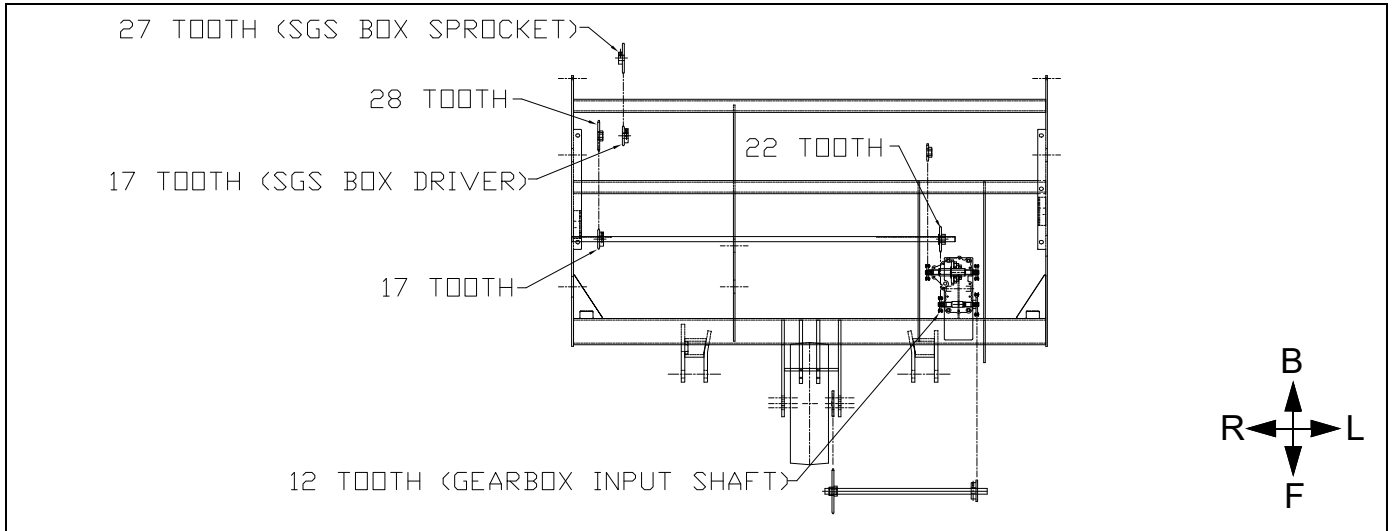

Figure 49
3P606NT Small Seeds (Option)

23110

606NT Drives

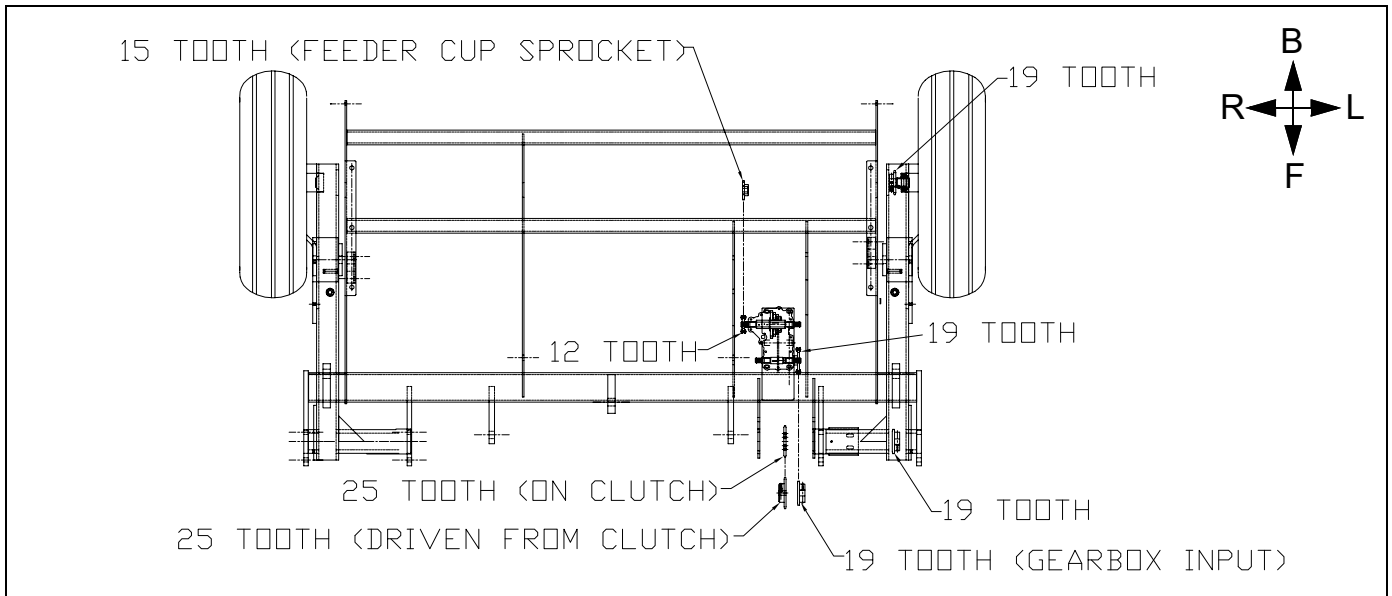

Figure 50
606NT Main Seed Box

23112

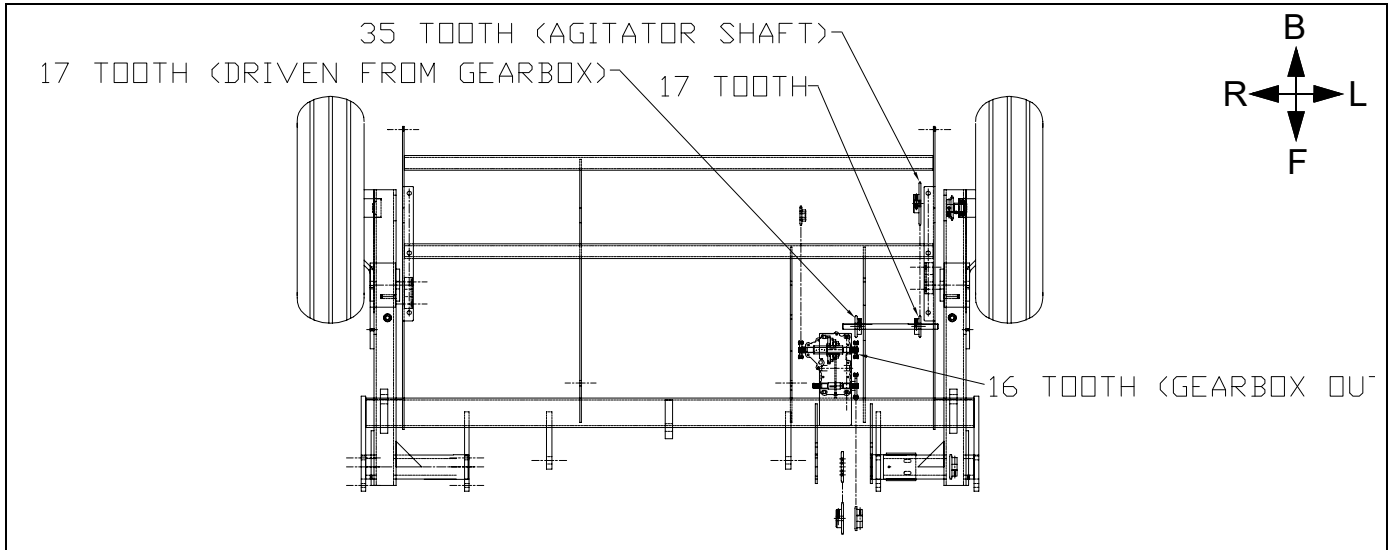

Figure 51
 606NT Main Seed Box Agitator (Option)

23112

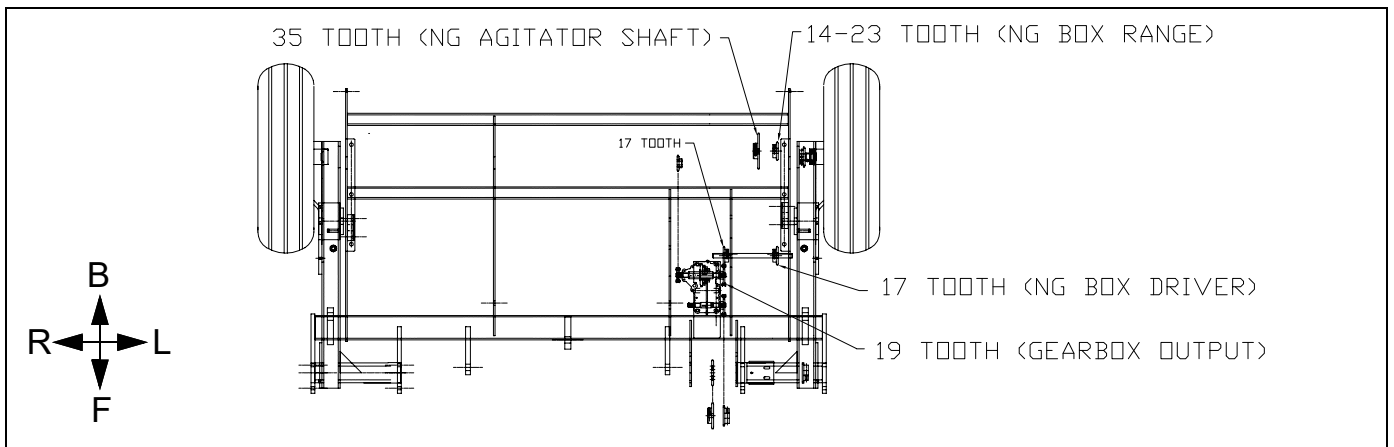

Figure 52
 606NT Native Grass (Option)

23109

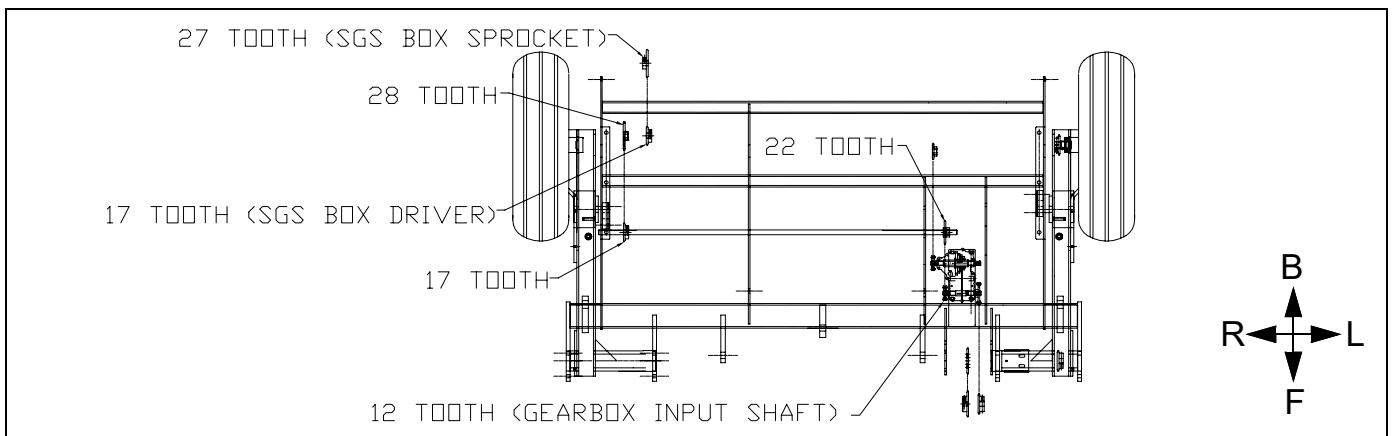

Figure 53
 606NT Native Grass (Option)

23109

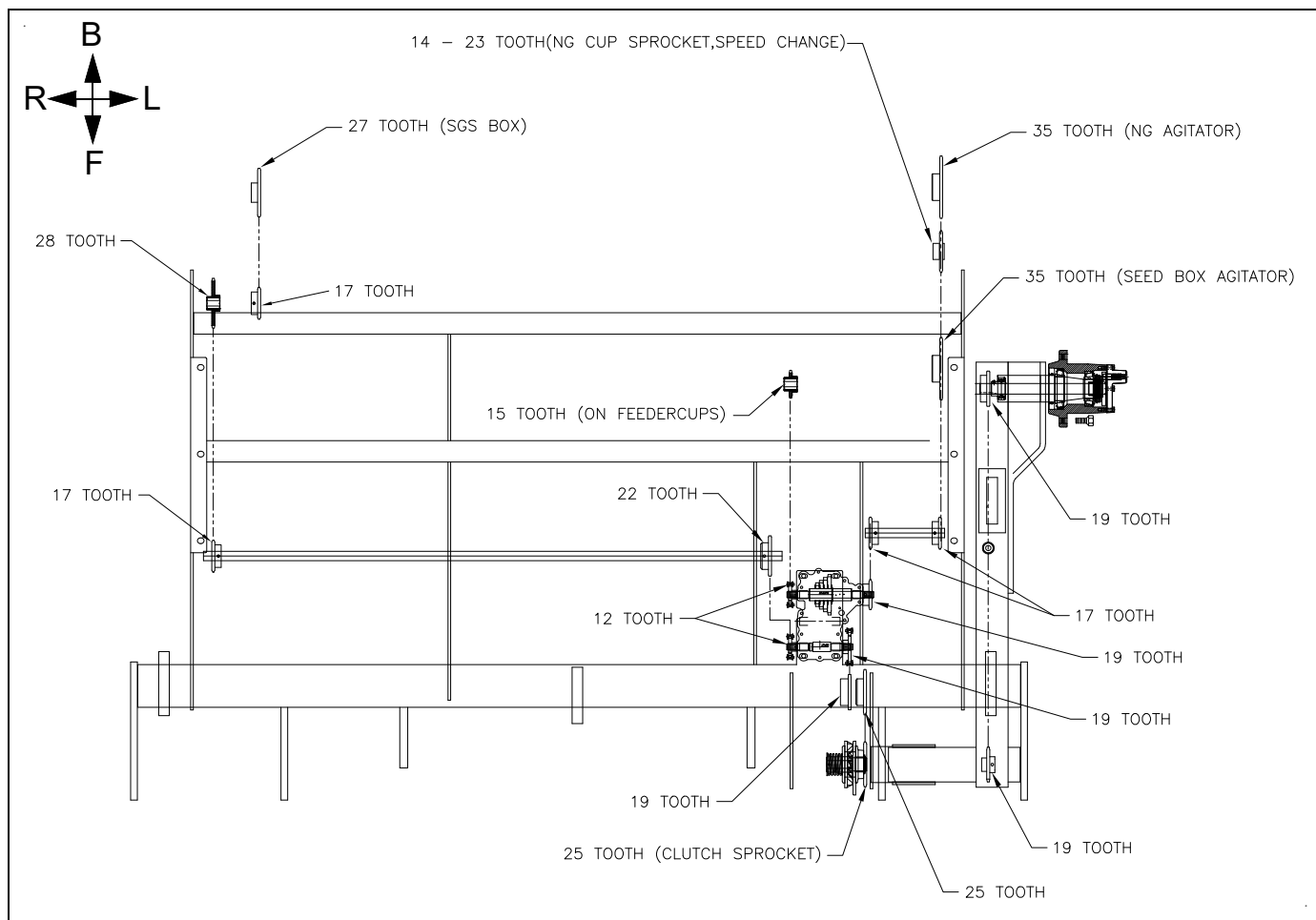

Figure 54
606NT Maximum Configuration

23212

Appendix B - Pre-Delivery

This section covers dealer requirements for assembly. As the dealer, it is your responsibility to unload, assemble and prepare the drill for use.

The drill is shipped via flat bed truck. Unload all equipment before beginning assembly. Do not attempt any assembly work while the drill is on the truck.

The following sections are step-by-step instructions for assembling the drill. Begin with *Tools Required* and *Pre-Assembly Checklist* to ensure you have all necessary parts and equipment at hand. Then proceed with *Install Gauge Wheels*. Follow each step to make the job as quick and safe as possible and produce a properly working machine.

Tools Required

- Properly rated forklift with 3-pt adapter to lift the drill, or two forklifts with the properly rated combined capacity for the drill, or overhead hoist, or loader with 6,500-pound capacity
- Hand jack
- General hand tools
- Jack stands, blocks and safety chain

Pre-Assembly Checklist

1. Read and understand “Important Safety Information” on page 1 before assembling.
2. Have at least two people on hand while assembling.
3. Make sure the assembly area is level and free of obstructions (preferably an open concrete area).
4. Have all major components.
5. Have all fasteners and pins shipped with the drill.
Note: If a pre-assembled part or fastener is temporarily removed, remember where it goes. Keep the parts separated.
6. Have a copy of the parts manual on hand. If unsure of proper placement or use of any part or fastener, refer to the parts manual.
7. Check that all working parts are moving freely, bolts are tight, and cotter pins are spread.
8. Check for proper tension and alignment on all drive chains.
9. Check that all safety labels and reflectors are correctly located and legible. Replace if

improperly located or damaged. Refer to *Safety Labels*, “**Important Safety Information**” in the operator’s manual.

10. Inflate tires to recommended pressure as listed on the *Tire Inflation Chart* in “**Appendix A**” on page 60. Tighten wheel bolts as specified on *Torque Values Chart* in “**Appendix A**” on page 61.

Unloading Location Requirements

Until unloaded, the drill cannot be moved using a tractor. The drill needs to be unloaded directly above the spot where final assembly takes place:

- On a flat, level, and dry surface,
- With adequate space to pull the trailer out from under the lifted drill without turns,
- With adequate space at the front and rear of the drill to easily maneuver forklifts
- With at least 10 ft. (3 m) clearance behind the press wheels,
- With tractor access in front.

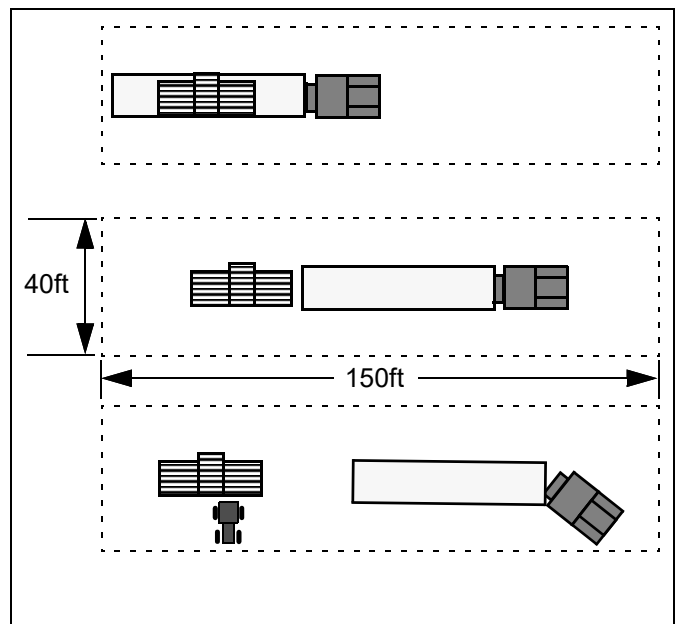

Suggested Unload Clearances

Unloading

Crushing Hazard:

Keep all bystanders away from unloading area. Use properly rated forklifts for unloading drill from trailer.

1. Unload all miscellaneous crates first. Place them well out of the area needed for unloading the drill.
2. If using two forklifts, position one forklift at the front and one at the rear of the drill.

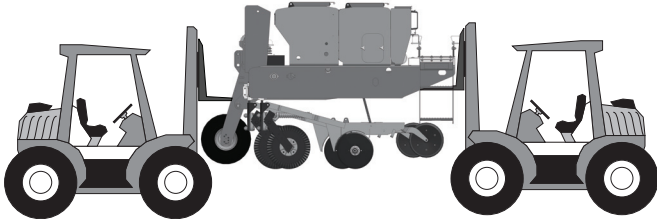

- On the front forklift, position the forks between two openers, under the front frame tube.
- On the rear forklift, position the forks under the rear frame tube.

Machine Damage Risk:



Do not use straps to unload the drill. Lift the drill by the frame tubes only. Do not lift the drill by the seed cups or seed cup channels.

Make sure the forklift forks are located between openers on the front frame tube.

3. Slowly lift the drill off the trailer bed.
4. Stop lifting about 12 inches off the trailer bed.
5. Slowly pull the trailer straight out from under the drill.
6. Making sure to keep the drill level front-to-back and side-to-side, slowly lower the drill to the ground 12 inches off the ground.

7. Remove nuts and u-bolts from the two shipping stands (3).

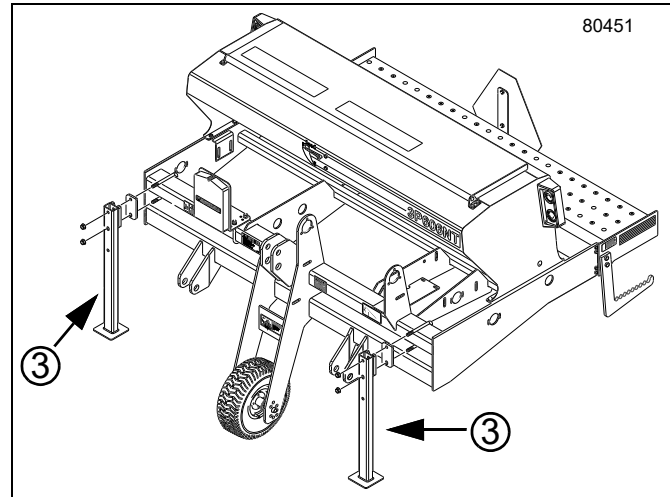

8. Remove shipping stands and rubber pads from the drill.
9. Slowly lower the drill to the ground.
10. Lower the forks and withdraw forklifts.

Attach Meter Hoses at Rows

All meter hoses are shipped disconnected at the row units. Clamps are shipped inside a seed box. The opener frame has openings for up to three material hoses:

- The forward hole (f) is always used for the seed delivery tube for the main seed box.
- The center hole (c) is used for Native Grass, if installed.
- The rear hole (r) is used for Small Seeds, if installed.

Start with the left row unit (row 1). For each row:

Refer to Figure 55

Main Seed Hose

Select one:

(17) 800-008C CLAMP HOSE 1 1/2 NO. 24

Open the clamp (17). Place it onto the outlet end of the hose (39), up against the ribs. Slide the outlet end of the hose fully onto the seed tube inlet (43) at the forward row unit opening (f). Move the clamp to just below the raised lip of the seed tube inlet.

Native Grass Hose

Select one:

(19) 800-346C CLAMP HOSE 2 5/8 #42

Open the clamp (19). Place it onto the outlet end of the hose (40), up against the ribs. Slide the outlet end of the hose fully onto the native grass tube inlet (45) at the center row unit opening (c). Move the clamp to halfway onto the hose neck.

Small Seeds Hose

Select one:

(18) 800-321C HOSE CLAMP NO.12 3/4 ID

Open the clamp (18). Place it onto the outlet end of the hose (42), up against the ribs. Slide the outlet end of the hose fully onto the small seeds tube inlet (12) at the rear row unit opening (r). Move the clamp to halfway onto the hose neck.

Note: These items are normally completed by the dealer prior to delivery.

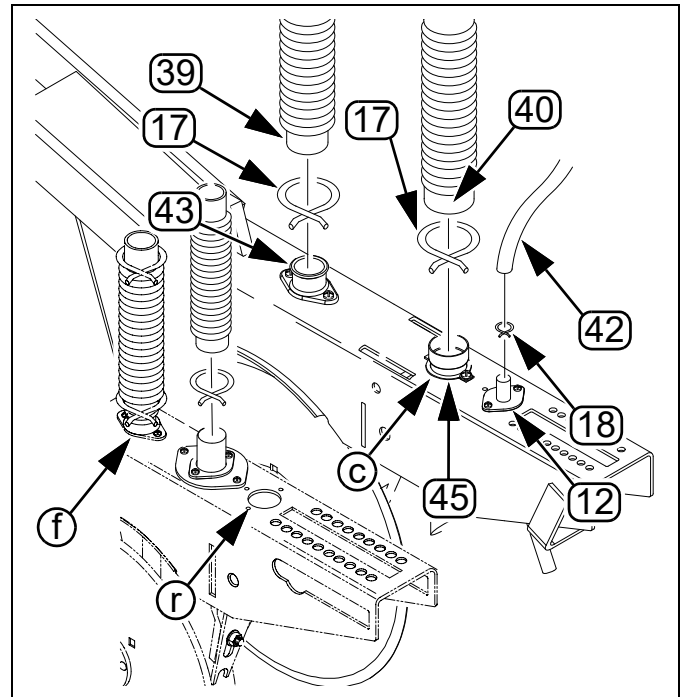

Figure 55
Seed and Native Grass Hoses

32683

Install SMV Reflector

Refer to Figure 56

The SMV reflector (46) is shipped pre-assembled to the mount (48), but mounted inverted on the walkboard. The SMV must be repositioned to upright to prevent contact with row units during operation.

Remove and save two sets:

(21) 802-007C HHCS 5/16-18X3/4 GR5

(30) 804-009C WASHER LOCK SPRING 5/16 PLT

(25) 803-008C NUT HEX 5/16-18 PLT

Orient the reflector assembly (48) upright, and red/orange reflective side to rear. Secure mount (48) to walkboard with bolts (21), lock washers (30) and nuts (25).

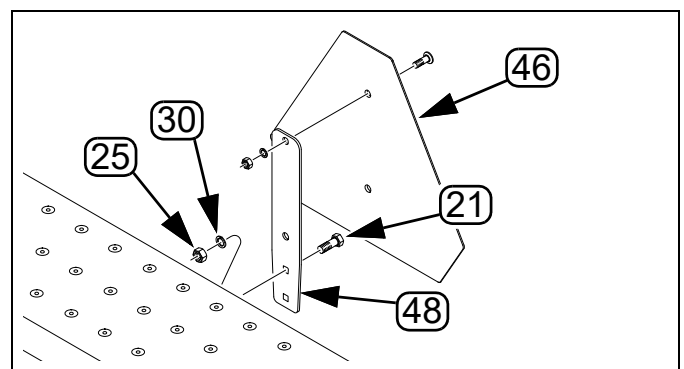

Figure 56
SMV Reflector

32648

Appendix C - Accessory Installation

Carbide Disc Scraper Installation

These instructions apply to an installation of scraper kit part number 121-781A.

Optional carbide disc scrapers are not factory installed. Start with row 1 (left-most row unit):

11. Remove one or both disc blades to gain safe access to the mount ①. Note the position of bushings and spacers for correct re-assembly (page 36).
12. Remove the existing slotted scraper.

Refer to Figure 57

13. Select one:

②③ 802-079C HHCS 3/8-16X1 1/4 GR5

If Seed-Lok[®] is present, or also being mounted, also select one:

③③ 804-013C WASHER LOCK SPRING 3/8 PLT

Place the lock washer ③③ on the bolt ②③ (because the nut is not used).

14. Select one:

③② 804-012C WASHER FLAT 3/8 SAE PLT

Place this flat washer on the bolt.

15. Select one:

890-357C SCRAPER-SPRING LOAD-AIR DESIGN

If the blades were not completely pre-assembled, select one each:

⑤① K7090 AIR DESIGN SCRAPER LH SIDE

⑤① K7091 AIR DESIGN SCRAPER RH SIDE

⑤③ K7096 SPACER AND WASHER ASSEMBLY

⑤② K7093 AIR DESIGN SCRAPER 15LB SPRING

Nest one side (⑤①, ⑤①) behind the other. Connect the spring ⑤② between the sides, using the small top holes. Insert the spacer ⑤③ from the front, with the narrow raised center to the rear (in the large blade holes).

16. Insert the bolt through the scraper blades (⑤①, ⑤①) and spacer ⑤③.

17. If no Seed-Lok[®] is present, select one each:

③③ 804-013C WASHER LOCK SPRING 3/8 PLT

②⑥ 803-014C NUT HEX 3/8-16 PLT

Secure the scraper assembly to the scraper mount ① using the lock washer ③③ and nut ②⑥.

If a Seed-Lok[®] is present (not shown), secure the scraper assembly to the Seed-Lok[®], using a threaded hole present in the Seed-Lok[®]. The hex nut is ②⑥ unused.

18. Re-mount the removed disc blade.

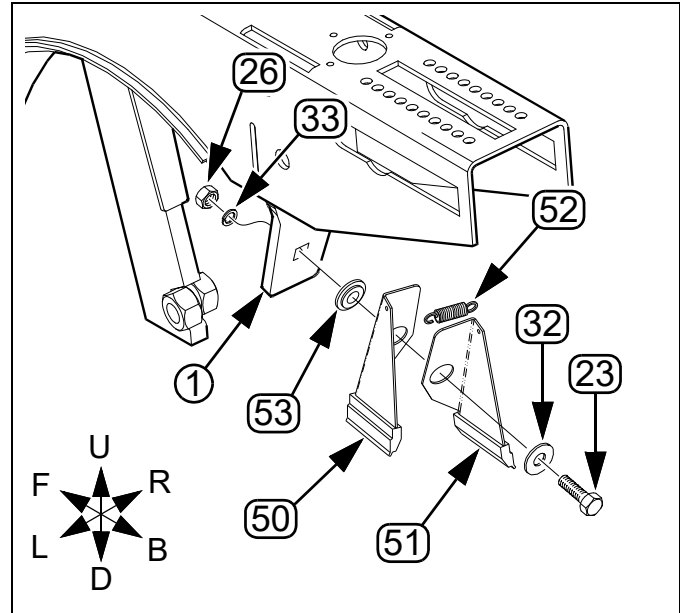

Figure 57
Carbide Disc Scraper Installation

19000

Weight Bracket Installation

These instructions apply to an installation of an optional 151-058A82 weight bracket kit.

Refer to **Figure 58**

1. Select one:
 (13) 151-134H82 WEIGHT BRACKET WELDMENT
 Select two:
 (37) 806-007C U-BOLT 3/4-10X4 1/32X4 1/2
 Select four sets:
 (36) 804-023C WASHER LOCK SPRING 3/4 PLT
 (28) 803-027C NUT HEX 3/4-10 PLT
2. Position the weight bracket weldment (13) at the left end of the top front frame tool bar. Orient the beveled edges and upper bracket to the back.
3. Install the U-bolts (37).
4. Secure the weldment (13) to the tool bar with the lock washers (36) and nuts (28).
5. Examine the weights to be used, and determine how to install the weight bracket adjustment legs. The orientation depicted is not optimal for all weights.
6. Select one:
 (14) 151-271D82 WEIGHT BRACKET ADJ LEG
 and two sets:
 (22) 802-055C HHS 5/8-11X2 GR5
 (34) 804-021C WASHER FLAT 5/8 SAE PLT
 (35) 804-022C WASHER LOCK SPRING 5/8 PLT
 (27) 803-021C NUT HEX 5/8-11 PLT
7. Secure the weight bracket adjustment leg (14) to the upper bracket with the bolts (22), flat washers (34), lock washers (35) and nuts (27). Depending on how your weights lock, it may be necessary to leave the bolts loose until after the weights are mounted.
8. Select one:
 (47) 838-265C DECAL REFLECTOR AMBER 2x9
 (16) 151-446D 10 GA 9.5 X 2.5 DECAL BRACKET
 (38) 806-263C U-BOLT 3/8-16X4 1/32X5
 Select two
 (31) 804-011C WASHER FLAT 3/8 USS PLT
 (33) 804-013C WASHER LOCK SPRING 3/8 PLT
 (26) 803-014C NUT HEX 3/8-16 PLT
9. Install the U-bolt (38) in the lower front frame tube.
10. Install the decal mount (16) on the U-bolt.
11. Install the flat washers (31), lock washers (33), and nuts (26) on the U-bolt.
12. Install the amber reflector decal (47) on the decal mount.
13. Repeat the above steps for the opposite side of the drill.

See frame weight information on page 30 for weight selection.

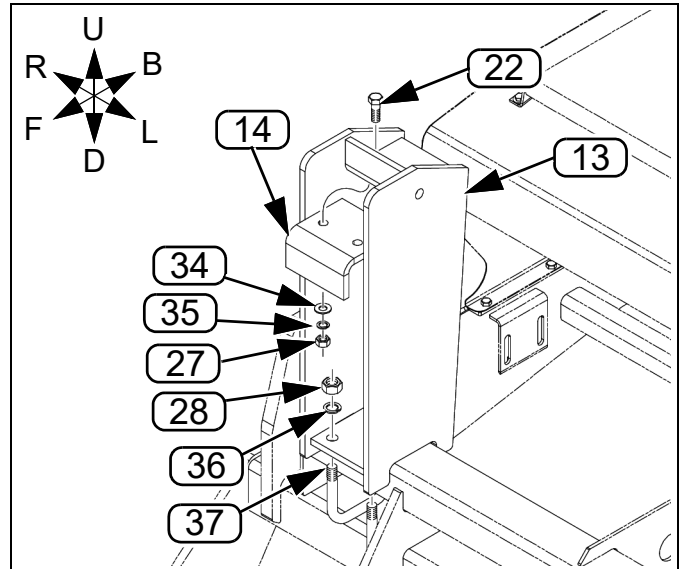

Figure 58
Weight Bracket Installation

18562A

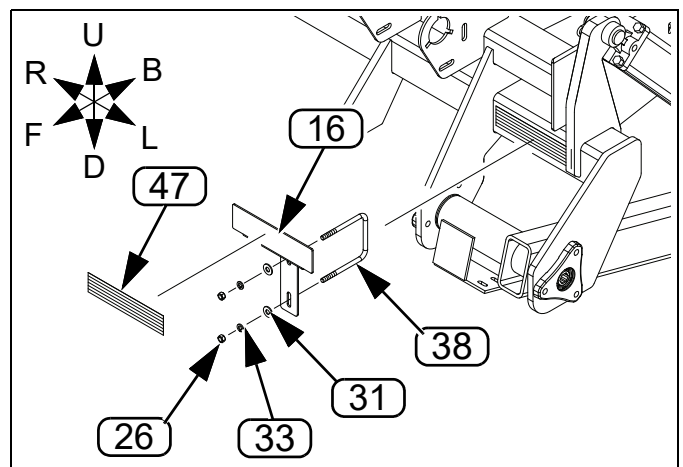
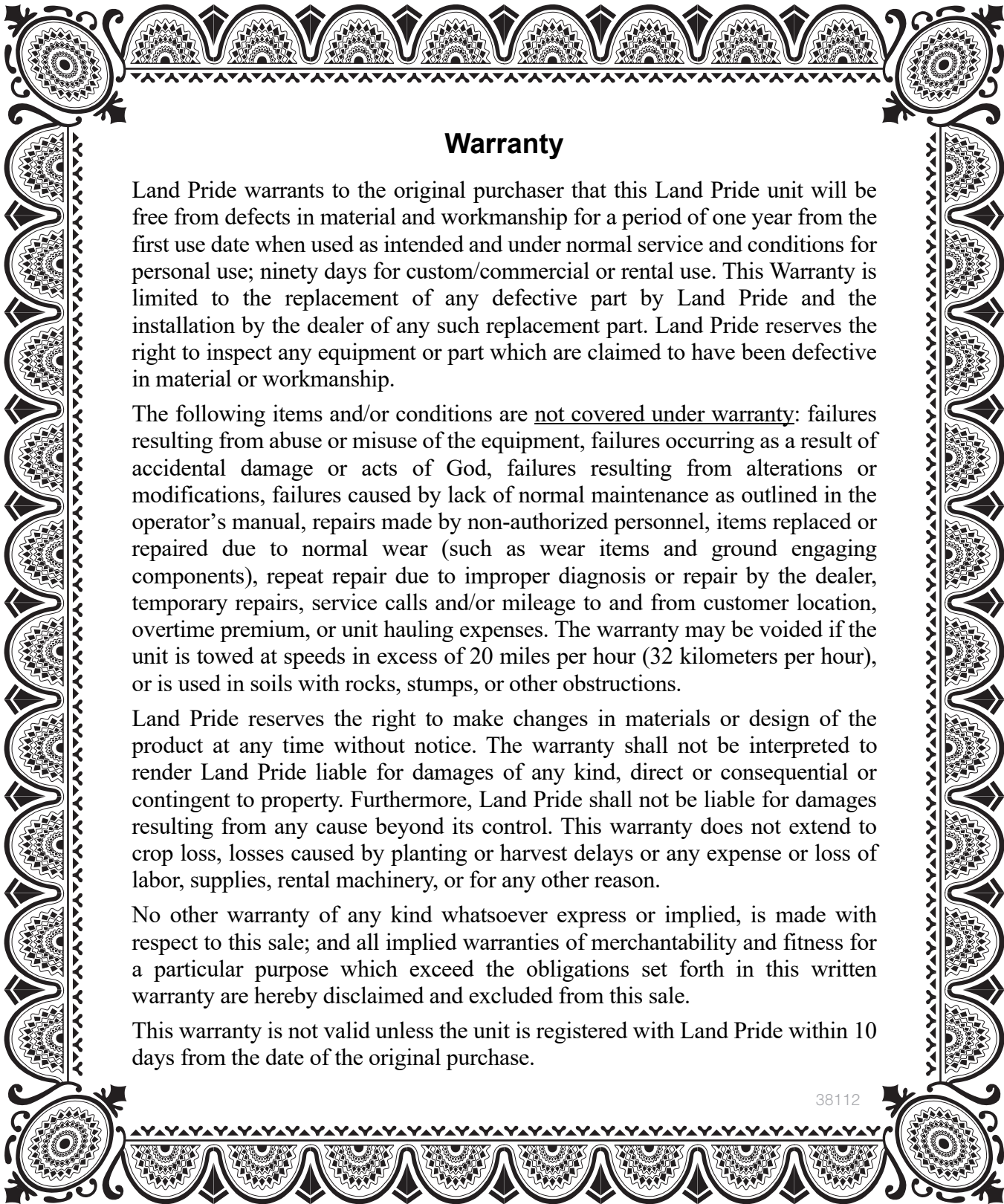

Figure 59
Reflector Installation

18621A





Warranty

Land Pride warrants to the original purchaser that this Land Pride unit will be free from defects in material and workmanship for a period of one year from the first use date when used as intended and under normal service and conditions for personal use; ninety days for custom/commercial or rental use. This Warranty is limited to the replacement of any defective part by Land Pride and the installation by the dealer of any such replacement part. Land Pride reserves the right to inspect any equipment or part which are claimed to have been defective in material or workmanship.

The following items and/or conditions are not covered under warranty: failures resulting from abuse or misuse of the equipment, failures occurring as a result of accidental damage or acts of God, failures resulting from alterations or modifications, failures caused by lack of normal maintenance as outlined in the operator’s manual, repairs made by non-authorized personnel, items replaced or repaired due to normal wear (such as wear items and ground engaging components), repeat repair due to improper diagnosis or repair by the dealer, temporary repairs, service calls and/or mileage to and from customer location, overtime premium, or unit hauling expenses. The warranty may be voided if the unit is towed at speeds in excess of 20 miles per hour (32 kilometers per hour), or is used in soils with rocks, stumps, or other obstructions.

Land Pride reserves the right to make changes in materials or design of the product at any time without notice. The warranty shall not be interpreted to render Land Pride liable for damages of any kind, direct or consequential or contingent to property. Furthermore, Land Pride shall not be liable for damages resulting from any cause beyond its control. This warranty does not extend to crop loss, losses caused by planting or harvest delays or any expense or loss of labor, supplies, rental machinery, or for any other reason.

No other warranty of any kind whatsoever express or implied, is made with respect to this sale; and all implied warranties of merchantability and fitness for a particular purpose which exceed the obligations set forth in this written warranty are hereby disclaimed and excluded from this sale.

This warranty is not valid unless the unit is registered with Land Pride within 10 days from the date of the original purchase.

38112

Model Number: _____

Serial Number: _____

[Table of Contents](#)



Corporate Office: P.O. Box 5060
Salina, Kansas 67402-5060 USA
www.landpride.com
